

Mr. E. B. Peacock 3323

# ELECTRICAL COMMUNICATION

*Technical Journal of the  
International Telephone and Telegraph Corporation  
and Associate Companies*

- PORT ELIZABETH-UITENHAGE TIME-SHARING-MODULATION RADIO LINK
- CRYSTAL CONTROL AT 1000 MEGACYCLES FOR AERIAL NAVIGATION
- DEVELOPMENT OF TOLL TRAFFIC IN SWITZERLAND, 1921-1947
- ANTENNA IMPEDANCE MEASUREMENT BY REFLECTION METHOD
- EXPERIMENTAL ULTRA-HIGH-FREQUENCY MULTIPLEX BROADCASTING
- BAND FILTERS USING PIEZOELECTRIC CRYSTALS IN LATTICES
- INFLUENCE OF SIGNAL IMITATION ON VOICE-FREQUENCY SIGNALS
- IMPEDANCE MEASUREMENTS WITH DIRECTIONAL COUPLERS



Volume 26

DECEMBER, 1949

Number 4

## **Electrical Communication**

**Index to Volumes 1-25**

**1922-1948**

A cumulative index for the first 25 volumes of **ELECTRICAL COMMUNICATION** has been prepared. Both author and subject indexes are included and the latter is extensively cross referenced. Copies may be obtained at \$1.00 each (payable in New York funds), postpaid, from **ELECTRICAL COMMUNICATION**, 67 Broad Street, New York 4, New York.



# ELECTRICAL COMMUNICATION

*Technical Journal of the*  
INTERNATIONAL TELEPHONE AND TELEGRAPH CORPORATION  
*and Associate Companies*

H. P. WESTMAN, Editor

F. J. MANN, Managing Editor

J. E. SCHLAIKJER, Editorial Assistant

### REGIONAL EDITORS

- E. G. PORTS, Federal Telephone and Radio Corporation, Newark, New Jersey
- B. C. HOLDING, Standard Telephones and Cables, Limited, London, England
- P. F. BOURGET, Laboratoire Central de Télécommunications, Paris, France
- H. B. WOOD, Standard Telephones and Cables Pty. Limited, Sydney, Australia

### EDITORIAL BOARD

- |                   |               |                  |                 |               |                |
|-------------------|---------------|------------------|-----------------|---------------|----------------|
| H. Busignies      | H. H. Buttner | G. Deakin        | E. M. Deloraine | W. T. Gibson  | Sir Frank Gill |
| W. Hatton         | E. Labin      | A. W. Montgomery | Haraden Pratt   |               | G. Rabuteau    |
| F. X. Rettenmeyer | T. R. Scott   | C. T. Strong     | A. E. Thompson  | E. N. Wendell | W. K. Weston   |

Published Quarterly by the

INTERNATIONAL TELEPHONE AND TELEGRAPH CORPORATION  
67 BROAD STREET, NEW YORK 4, N.Y., U.S.A.

Sosthenes Behn, Chairman                      William H. Harrison, President  
Charles D. Hilles, Jr., Vice President and Secretary

*Subscription, \$2.00 per year; single copies, 50 cents*

Electrical Communication is indexed in Industrial Arts Index  
Copyrighted 1949 by International Telephone and Telegraph Corporation

Volume 26

December, 1949

Number 4

## CONTENTS

	PAGE
PORT ELIZABETH-UITENHAGE TIME-SHARING-MODULATION RADIO LINK .....	269
CRYSTAL CONTROL AT 1000 MEGACYCLES FOR AERIAL NAVIGATION .....	272
<i>By S. H. Dodington</i>	
DEVELOPMENT OF TOLL TRAFFIC IN SWITZERLAND, 1921-1947 .....	279
<i>By H. Stoeri</i>	
ANTENNA IMPEDANCE MEASUREMENT BY REFLECTION METHOD .....	285
<i>By Edwin Istvánffy</i>	
EXPERIMENTAL ULTRA-HIGH-FREQUENCY MULTIPLEX BROADCASTING SYSTEM ..	292
<i>By A. G. Kandoian and A. M. Levine</i>	
CALCULATION OF BAND-PASS FILTERS USING PIEZOELECTRIC CRYSTALS IN LATTICE STRUCTURES .....	305
<i>By A. Fromageot and M. A. Lalande</i>	
INFLUENCE OF SIGNAL IMITATION ON RECEPTION OF VOICE-FREQUENCY SIGNALS	319
<i>By T. H. Flowers and D. A. Weir</i>	
IMPEDANCE MEASUREMENTS WITH DIRECTIONAL COUPLERS AND SUPPLEMENTARY VOLTAGE PROBE .....	338
<i>By B. Parzen</i>	
RECENT TELECOMMUNICATION DEVELOPMENTS	
STOCKHOLM-GÖTEBORG COAXIAL TELEPHONE CABLE .....	284
KELVIN PREMIUM TO EARP AND GODFREY .....	304
CONTRIBUTORS TO THIS ISSUE .....	344



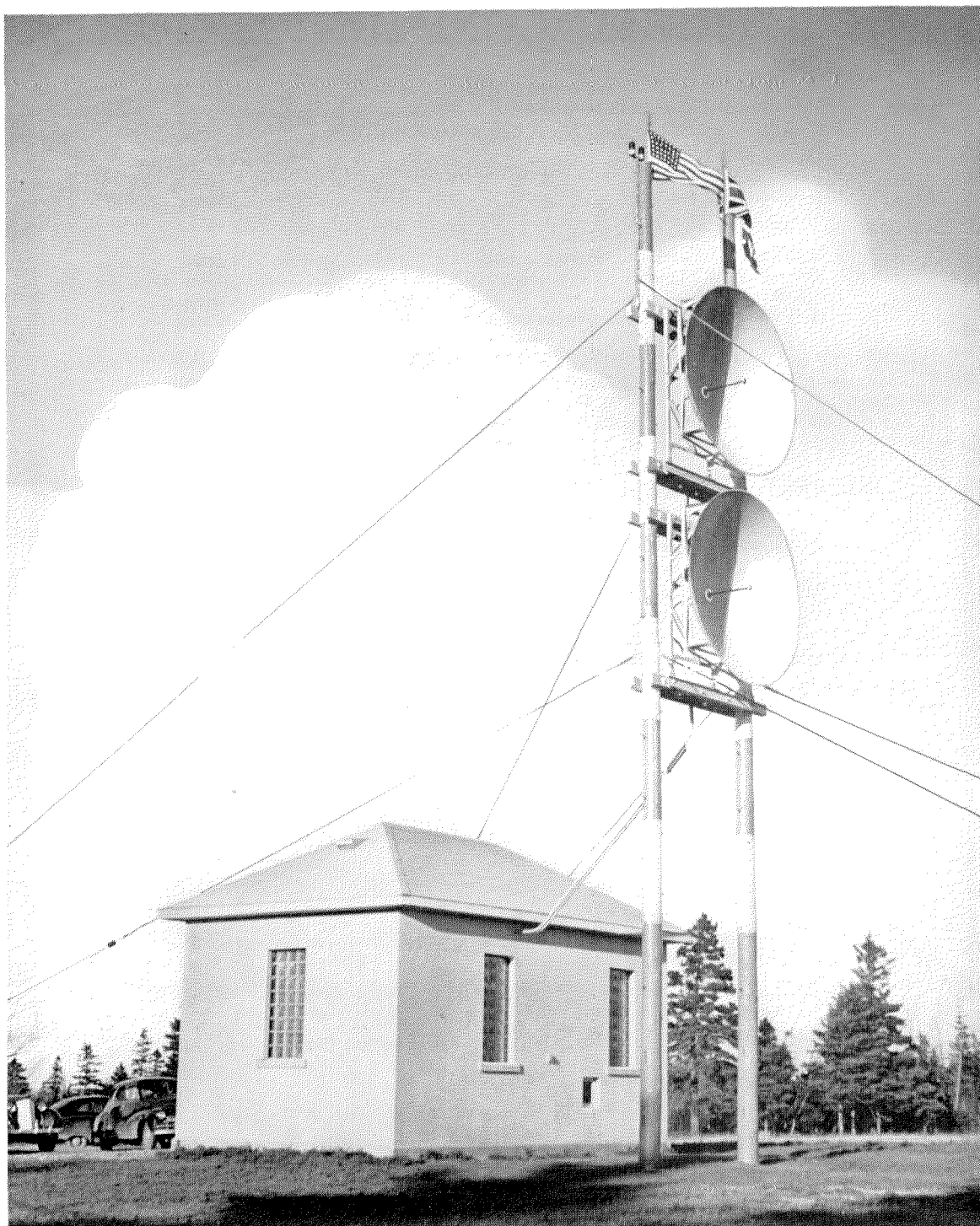

**This microwave radiotelephone terminal at Fraser's Mountain near New Glasgow, Nova Scotia, together with a similar installation at Tea Hill, Charlottetown, Prince Edward Island, provide 23 telephone circuits across Northumberland Strait, noted for the ability of its winter storms in breaking submarine cables. The first commercial installation of its kind in the world, this 46-mile 2000-megacycle link uses pulse-time modulation. It was constructed for the Maritime Telephone and Telegraph Company of Halifax and the Island Telephone Company of Prince Edward Island by Federal Electric Manufacturing Company of Montreal, Canada.**

## Port Elizabeth–Uitenhage Time-Sharing-Modulation Radio Link

**T**HE Port Elizabeth–Uitenhage radio link was installed during the latter part of 1948 and was handed over to the South African Post Office for commercial traffic on the first day of November of that year.

The link provides 24 telephone circuits between Port Elizabeth and the neighbouring town of Uitenhage. The latter is an increasingly important industrial town and the eight telephone lines previously available to Port Elizabeth were becoming so inadequate that delays of several hours were occurring during peak traffic periods.

It was considered that the simplest way to overcome this delay was by the installation of a radio link, and the time-sharing-modulation system<sup>1</sup> of Standard Telephones and Cables, Limited was selected. The equipment at each terminal consists of a radio transmitter and receiver operating between 400 and 500 megacycles per second, together with all the necessary pulse-generating and channelling apparatus. The receiver and transmitter are contained in individual cabinets and the necessary terminating and signalling equipment is mounted on a separate 19-inch rack. The aerial system comprises a half-wave dipole mounted in a corner-type reflector. Transmitting and receiving aerials are identical and each has a gain of approximately 9 decibels. The aerials are mounted on 125-foot lattice towers and each is connected to its equipment via 150 feet of solid polythene coaxial cable having a loss of approximately 4.5 decibels. Both an-

tenna supports are identical and the Port Elizabeth mast is shown in Figure 1.

The air-line distance between the aerials is approximately 23.5 kilometres (14.6 miles) and the route passes through a shallow depression in a range of low hills at about 8 kilometres (5 miles) from the Uitenhage terminal. The calculated free-space loss for the circuit is approximately 112 decibels and measurements suggest that the total loss is about 107 decibels.

This attenuation has been measured and gives values within 4 decibels over the 400-to-500-

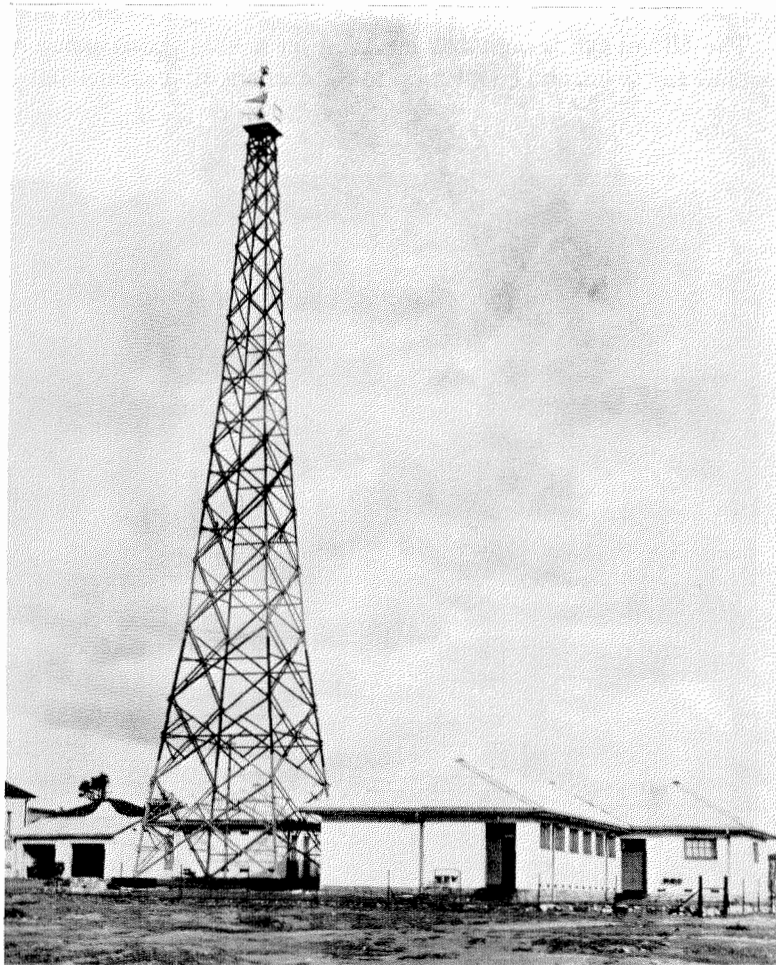

Figure 1—Port Elizabeth antenna system. The half-wave dipole mounted in a corner-type reflector is at the top of the 125-foot lattice tower.

<sup>1</sup> Similar to pulse-time modulation.

megacycle band, which suggests that multiple reflections of low amplitude are being received from the line of hills mentioned above.

The system operates on a frequency of approximately 475 megacycles between Port Elizabeth and Uitenhage and 440 megacycles in the reverse direction. The peak power of the transmitters is about 150 watts.

The Port Elizabeth terminal is installed in the carrier terminal station at Neal Street, and connections to the central exchange are via a multi-pair telephone cable. The loss in this cable is about 2 decibels. The space available for the equipment is limited and the transmitter bay (Figure 2) and receiver bay (Figure 3) are mounted back to back as shown in Figure 4. The terminating and signalling equipment is mounted on a standard 19-inch rack and is installed in a different part of the building.

The Uitenhage terminal is installed on a hill outside the town, and connection to the exchange

is via approximately 2 kilometres (1.24 miles) of multi-pair cable, having a loss of 3 decibels. This terminal is normally unattended and periodical maintenance visits are made by the Port Elizabeth staff. Alarm circuits, indicating a failure of any part of the equipment or unauthorized entry into the building, have been extended to the Uitenhage telephone exchange. The terminating and signalling apparatus is mounted on a standard 19-inch rack that is installed alongside the radio bays. Views of the transmitting and receiving bays, which are quite similar in appearance, are shown in Figures 2 and 3.

The system is now in continuous service and handles up to 300 calls per hour during peak periods. Five circuits are equipped with apparatus to enable the Uitenhage operators to dial directly into the Port Elizabeth telephone system. These circuits operate on a direct-current basis using the dialing impulses to off-set the channel pulses in the transmitter. The receiver

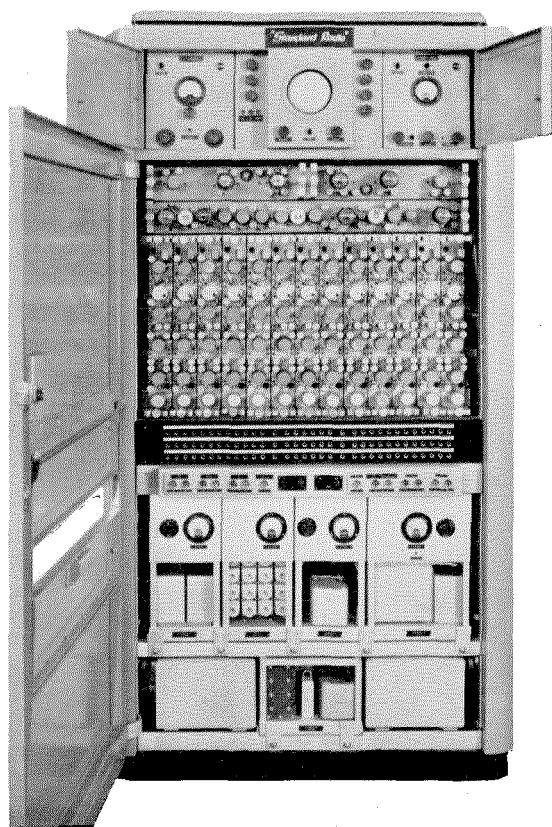

Figure 2—Front view of transmitter bay.

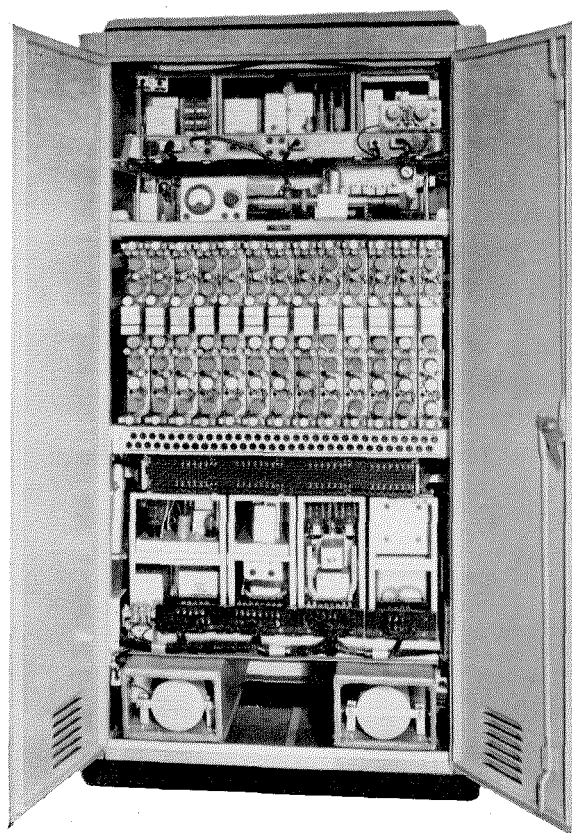

Figure 3—Rear view of receiver bay.

Figure 4—The transmitter and receiver at Port Elizabeth are arranged back to back because of limited space. The telephone terminating and signalling equipment is located elsewhere in the building.

incorporates a circuit that operates a relay in sympathy with the displacement of the transmitted pulse.

The remaining circuits are equipped with 17-cycle ringing apparatus in both directions. These circuits rectify the ringing alternating current and operate the direct-current signalling circuits of the system. In this case, a locally generated 17-cycle current is connected at the receiving end to operate the ringing apparatus at the switchboard.

The system is operating at a signal-to-noise ratio of better than 60 decibels on all circuits. Cross talk is also below 60 decibels on all channels. The overall equivalent of the system, between the switchboards, is -6 decibels.

Recent reports from the South African Post Office show that the system is working well and that no excessive maintenance is required.

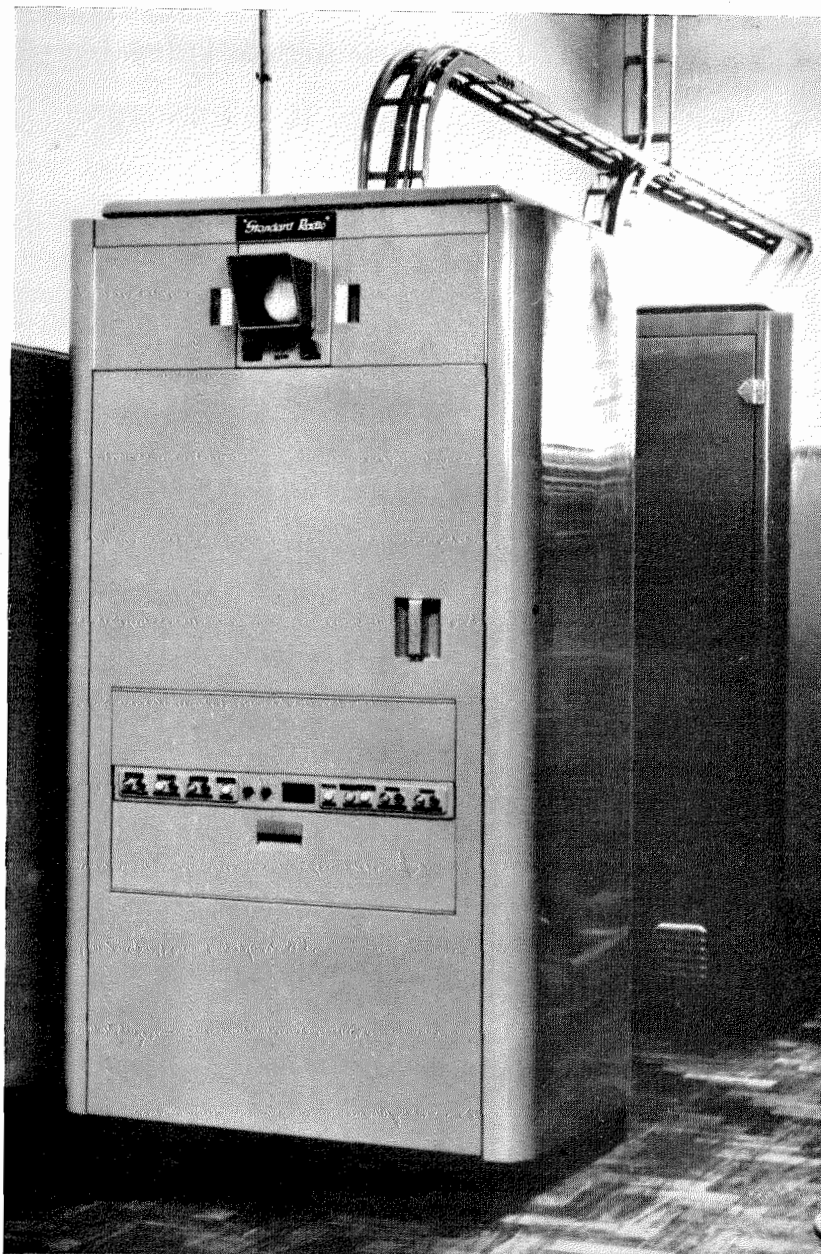

# Crystal Control at 1000 Megacycles for Aerial Navigation\*

By S. H. DODINGTON

*Federal Telecommunication Laboratories, Incorporated, Nutley, New Jersey*

**D**URING the summer of 1945, the problem arose of developing a new integrated system of aerial navigational aids based on the use of pulse techniques and built around the distance-measuring equipment, which appeared to be the most needed new navigational aid. It was desired that the fastest possible progress be made with the distance-measuring equipment and that the design be such that there could be multiplexed on it, using the same radio-frequency apparatus for both ground and air, a great many other functions, such as, new omnidirectional ranges, localizers, and glide-path systems, etc.

Among the immediate problems to be solved were the choice of transmission frequency, obtaining adequate frequency stability in the transmitter, and determining the maximum practical degree of selectivity in the receiver; these factors establish the channel spacing. It was hoped that 51 clear channels could be provided.

## 1. General Principles

The basic principles of a distance-measuring equipment<sup>1</sup> are shown in Figure 1. An airborne pulse transmitter interrogates a ground beacon consisting of a receiver and transmitter, and an airborne receiver sends the information contained in the reply from the beacon to an automatic ranging circuit, which computes the distance from the elapsed time between transmission and reception for display on a meter. It will be recognized that this is a development of wartime aircraft identification and other beaconry techniques, with the important difference that the display is on a meter rather than on a cathode-ray tube.

\* Presented, Institute of Radio Engineers National Convention, March 9, 1949, New York, New York.

<sup>1</sup> H. Busignies, "High-Stability Radio Distance-Measuring Equipment for Aerial Navigation," *Electrical Communication*, v. 25, pp. 237-243; September, 1948.

Using the best practical superheterodyne receivers in the aircraft and on the ground, the transmitter powers involved are of the order of 1 to 5 kilowatts for 100-mile line-of-sight coverage. The pulse-repetition rate of the airborne equipment averages about 40 per second, and that of the beacon, with 50 aircraft interrogating it, about 2000. Pulse duration is 1.5 microseconds.

While many interesting problems were encountered and solved in connection with the automatic ranging circuits that operate the meter display, this paper will be limited to the problems of frequency channelling.

## 2. Operating Frequency

A preliminary survey had shown that almost any frequency between 200 and 10,000 megacycles per second would provide the necessary performance, but further study indicated that the 1000-megacycle region offered most promise in the present state of the art. On an allocation basis, this appeared to be the lowest frequency at which 51 two-way clear channels could be

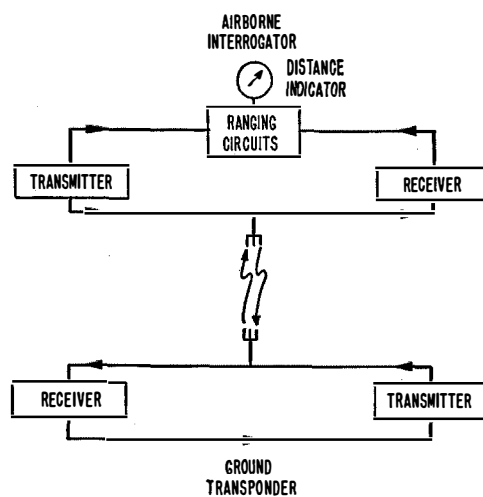

Figure 1—Elements of a distance-measuring system.



obtained, practically all of the spectrum below this band already having been assigned to other services. It appeared to be the highest frequency at which triodes could be used with reasonable efficiency, and it is sufficiently high in frequency to permit the use of simple low-drag aircraft antennas. Moreover, since crystal control of frequency was considered to be highly desirable, the problems of frequency multiplication were not as severe as they would be at higher frequencies. The 960-to-1215-megacycle aerial-navigation band was, consequently, chosen, and it was decided to use the lower half of the band for air-to-ground interrogation and the upper half for ground-to-air reply. This meant that if 51 channels were to be obtained, they could be not more than 2.5 megacycles wide.

### 3. Frequency Control of Receivers

It was decided at the outset that no major improvement in noise factor could be obtained at this frequency by the use of radio-frequency amplifiers. Accordingly, a silicon-crystal converter was used in a superheterodyne circuit. The power requirements for the local oscillator of such a converter are small enough to permit an economical crystal-oscillator and multiplier arrangement to be employed. The biggest problem was in the airborne equipment, where a tuning range of 120 megacycles was required with a minimum of ganging and tracking adjustments. This could be accomplished by using a crystal-oscillator and multiplier chain of sufficient bandwidth to cover this whole range merely by switching quartz crystals but without retuning any other circuits. This meant, of course, that there was serious danger of spurious responses due to the large number of harmonics generated by the broadband multiplier, but these could be reduced by the use of a good input preselector and by the use of the highest possible crystal-oscillator frequency. Crystal-oscillator frequencies from 42 to 47 megacycles were chosen with one crystal for each frequency, rather than to attempt any crystal-saving techniques that would involve either more-complicated circuitry or the addition of further spurious responses. The crystals were mounted in a simple light-weight turret. A two-stage preselector was provided between the antenna and the converter

and, using a 64-megacycle intermediate frequency, the over-all result was that the image frequency and all spurious responses were down by at least 60 decibels from the desired signal. To obtain reliable operation from the crystal oscillator (which used third- or fifth-mode harmonic crystals), it was found necessary to tune one element of the crystal oscillator and gang this to the shaft driving the turret and the

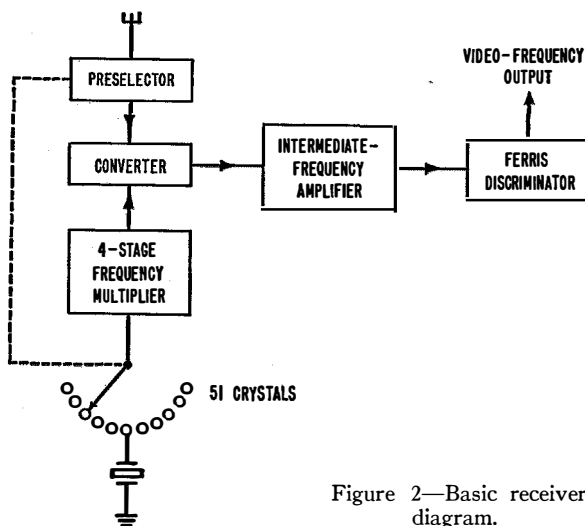

Figure 2—Basic receiver diagram.

preselector. No tracking problems were encountered, the tuning law of the quarter-wave coaxial preselector being almost linear. The ground-beacon receiver operated in essentially the same manner except, of course, that no tracking was necessary, fixed-frequency operation only being required. Figure 2 shows the general principles, and Figure 3 is a photograph of the airborne receiver components.

### 4. Frequency Control of Transmitters

A serious problem was that of stabilizing the frequency of the transmitters. Our first thoughts turned to conventional techniques using a pulsed crystal oscillator and multiplier chain. While its use on the ground might have been considered further, it appeared to be prohibitively costly in weight for airborne equipment. Preliminary experiments indicated that no fewer than seven tuned circuits would have to be ganged and tracked to obtain the necessary power of at least 1 kilowatt and, furthermore, it would be

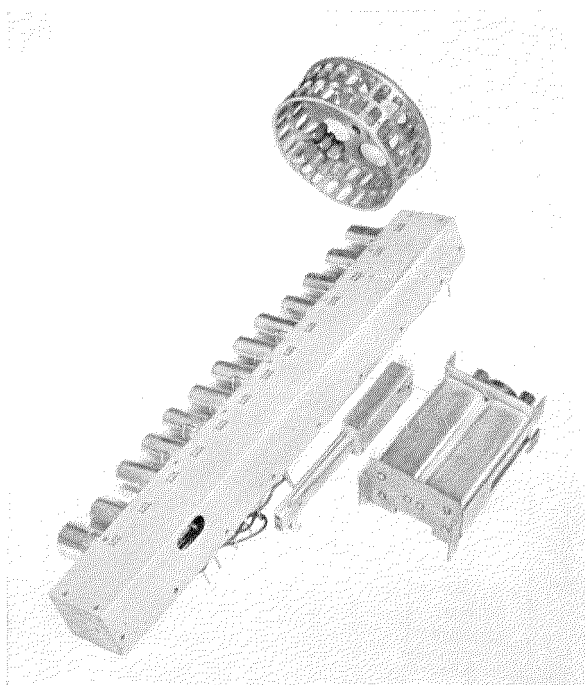

Figure 3—Airborne receiver components. The 51 crystals are assembled in the cylindrical housing.

necessary to pulse the low-level stages with a broad pulse, the leading edge of which preceded that of the pulse applied to the last stage, to get satisfactory build-up. Thus, not only were the radio-frequency problems severe but the modulator would have been exceedingly bulky.

An investigation was, therefore, made of an indirect crystal-control system in which a pulsed oscillator is used for transmission, its frequency being continuously compared with the output of a low-power crystal-oscillator and multiplier system and automatic correction applied to keep its frequency within certain limits. Since by this time the receiver problem had been solved, it appeared that if the difference between the transmitting and receiving frequencies were made twice the intermediate frequency and the local oscillator frequency were half-way between that of the transmitter and receiver, a single intermediate-frequency amplifier could provide gain for both the received signal and the sample of the transmitted frequency used to operate the automatic-frequency-control system. In effect, transmission occurs on the image frequency of the receiver.

The general plan of the system is shown in Figure 4. As the result of combining these two functions, effective control of transmission frequency is obtained in the airborne equipment with only five additional tubes used as intermediate-frequency amplifiers, discriminator, and motor controls to retune the transmitting oscillator when it deviates from the correct frequency. To prevent strong received pulses from operating the automatic-frequency-control arrangement, the intermediate-frequency amplifier stage preceding the discriminator is keyed by the same pulse that is applied to the transmitter. This stage is, therefore, inoperative at all other times.

A feature that was obtained as a by-product of this method of frequency control was the ability to change transmitter tubes without making any manual tuning adjustments, as the automatic frequency control was arranged to operate on the transmitter frequency if it was within 20 megacycles of the correct frequency. This characteristic was obtained quite simply by so arranging the motor control circuit that it tuned the transmitter continuously backwards and forwards over a  $\pm 20$ -megacycle range in the absence of any control signal, only stabilizing the transmitter frequency when such a signal was applied. Thus, a comparatively narrow-band high-stability discriminator could be used. The net result is an airborne transmitter, the frequency of which is maintained within 200 kilocycles of

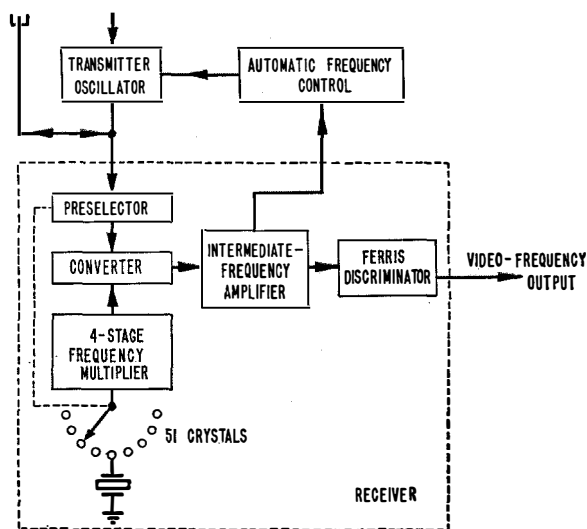

Figure 4—Indirect system of controlling the frequency of the pulsed transmitter.

the value set by the discriminator and crystal-oscillator-multiplier system. A further 200-kilocycle variation is permitted for the combined drift of these latter two elements. This includes all effects due to change in tubes either in the transmitter, discriminator, or crystal oscillator.

### 5. Transmitter Spectrum

The solution to the problem of stability of both receivers and transmitters did not end the channelling problem by any means, as the transmitted pulse spectrum was such that a comparatively strong signal was radiated over a large number of receiving channels, and no degree of receiver selectivity could improve this condition.

The pulses have a spectrum somewhat as shown in Figure 5A so that with a perfect receiver, having the selectivity curve shown in Figure 5B, the adjacent-channel response is down by only 22 decibels. Since some 60 decibels are required, this is obviously not good enough.

By increasing the rise and decay times of the transmitted pulse, the spectrum might be considerably narrowed but this would only be true if the transmitter "carrier" were maintained at constant frequency during modulation. However, with a normal pulsed oscillator, frequency modulation occurs as the voltage across the oscillator changes, often producing the unde-

sirable spectrum shown in Figure 5C. This spectrum is very hard to control, as it is influenced by feedback, mutual conductance, antenna loading, and other factors.

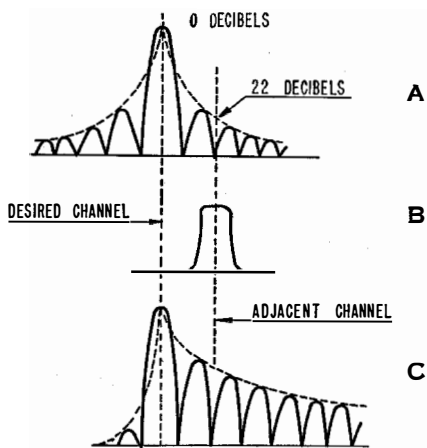

Figure 5—A is the pulse spectrum. B is the selectivity curve of a receiver tuned to the adjacent channel. C is a pulse spectrum resulting from frequency modulation of the transmitting oscillator.

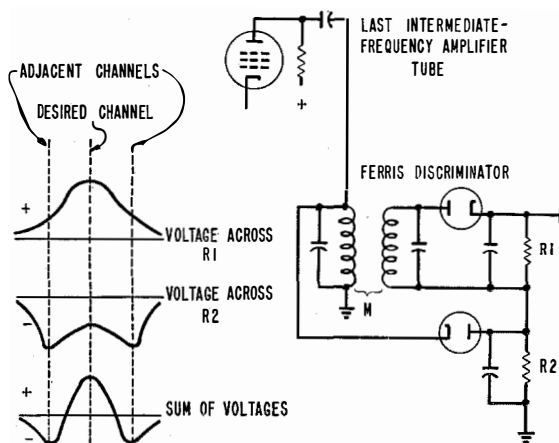

Figure 6—Ferris discriminator.

Instead, a pulse having the steepest possible rise and fall is used to produce an accurately predictable spectrum and the so-called Ferris discriminator is employed in the receiver to bring about satisfactory operation.

### 6. Ferris Discriminator

This circuit is named after H. A. Ferris, formerly of the Canadian National Research Council, and now with Trans-Canada Airlines. In the Ferris discriminator, the normal selectivity of the receiver is not controlling provided it is broad enough to accept at least three channels simultaneously, i.e., about 6 megacycles in the present system. Then, at the output of the intermediate-frequency amplifier, the circuit shown in Figure 6 is installed. As the intermediate frequency is varied, the steady-state response shown in the figure results. When a pulse is applied to this circuit, the distribution of positive and negative outputs depends on the symmetry of the spectrum with respect to the nominal center frequency of the intermediate frequency. Four typical conditions are shown in Figure 7. A pulse in the adjacent channel will cause a negative output even when 90 decibels above the on-channel threshold. This negative pulse is readily clipped in the succeeding stages so that

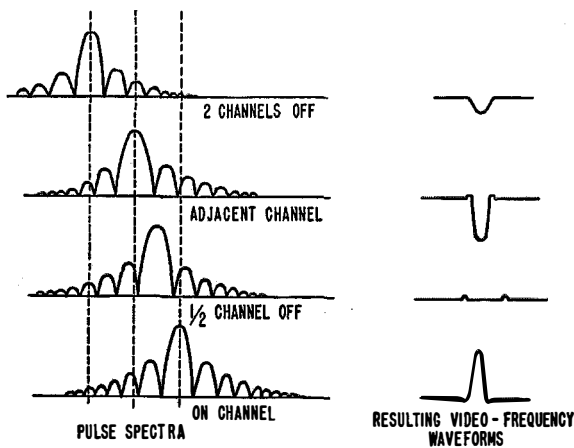

Figure 7—Video-frequency response of Ferris discriminator to pulse spectrum on the desired channel and for three conditions of off-channel operation.

the equipment sees, in effect, only those pulses whose spectra are very nearly centered on the correct frequency. Ignition noise and other random spectrum pulses produce predominantly negative pulses from the discriminator.

This system of discrimination, while ideal for distance-measuring equipment, where pulse distribution is entirely random, is not universally applicable to systems where there is a likelihood of two pulses often occurring at the same time. In such a case, a strong adjacent-channel pulse might "knock out" a simultaneous desired-channel pulse. Application of this principle,

therefore, must be carefully studied when other uses are considered.

Thus, by the use of a high-frequency crystal oscillator, broad-band multiplier, preselector, transmitter automatic frequency control, and the Ferris discriminator, a satisfactory channelling system was developed and permitted the over-all design of the equipment to be completed. The performance of this channelling system is as follows.

### 7. Channelling System

Fifty-one two-way channels are provided with a 2.4-megacycle channel spacing. The airborne peak power is 1 kilowatt and the beacon peak power is 5 kilowatts. The airborne sensitivity is 30 microvolts across 50 ohms and the beacon sensitivity is 15 microvolts across 50 ohms. Adjacent-channel rejection is better than 70 decibels, and image rejection and all spurious responses within the distance-measuring band are down by at least 60 decibels in both the air and ground equipments.

### 8. Packaging and Over-All Performance

Figure 8 is a view of the airborne radio-frequency system, all major components being visible except the crystal turret, which is behind the chassis. Figure 9 is an over-all view of the complete airborne equipment showing the general

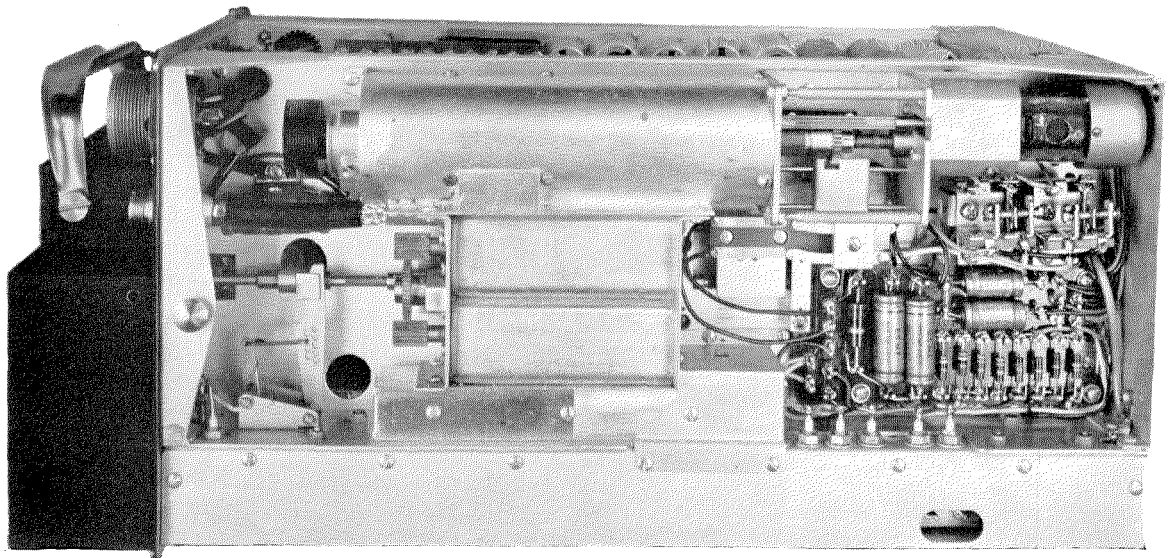

Figure 8—Radio-frequency system of airborne equipment.

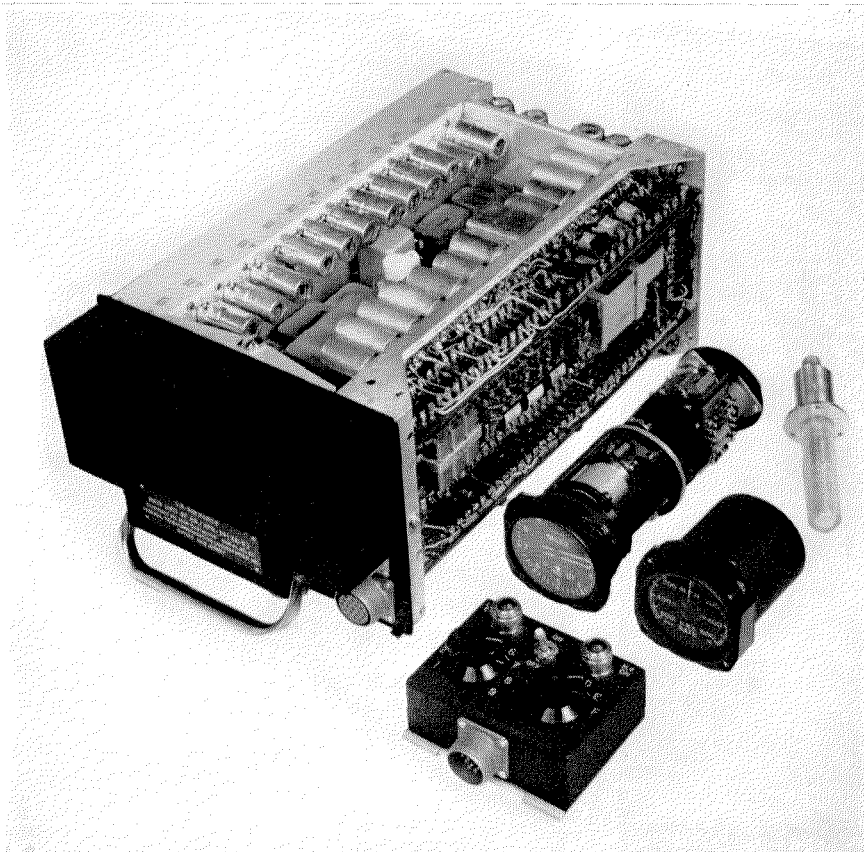

Figure 9—Complete airborne apparatus. The small control box and two indicators for distance and rate are all that need be mounted in the pilot's cockpit. The antenna is at the extreme right.

method of packaging in which the radio-frequency chassis is on one side of the equipment, the ranging circuit on the other side, the power supply and modulator in the center, and the automatic-frequency-control circuits are at the rear. Also shown are the control box and the distance and rate meters, which units are all that must be mounted in the pilot's compartment. The airborne antenna may be seen at the extreme right. Figure 10 is a rear view of the main unit of the airborne equipment, which weighs 36 pounds and has over-all dimensions of  $17\frac{1}{2}$  by 10 by  $7\frac{1}{2}$  inches. The total airborne weight is of the order of 45 pounds.

The ranging circuits provide a display of distance between 0 and 115 nautical miles to an accuracy of  $\frac{1}{3}$ th mile. The differential of the distance is displayed between 0 and  $\pm 600$  miles an hour to within an accuracy of about 10 percent; when flying a radial course with respect

to the beacon, this is equivalent to the ground speed of the aircraft.

Figure 11 shows the ground beacon viewed from the rear, the units, starting at the bottom, being the high-voltage supply, receiver, modulator, transmitter, transmitter automatic-frequency-control system, and monitor. Figure 12 is the ground-beacon antenna with its cover removed; this antenna consists of 9 discons stacked vertically to provide approximately 7 decibels gain towards the horizon.

The Radio Technical Committee for Aeronautics has now established a channeling system for an interim distance-

measuring equipment, which is expected to be installed on the airways of the United States during the next few years for use until the middle

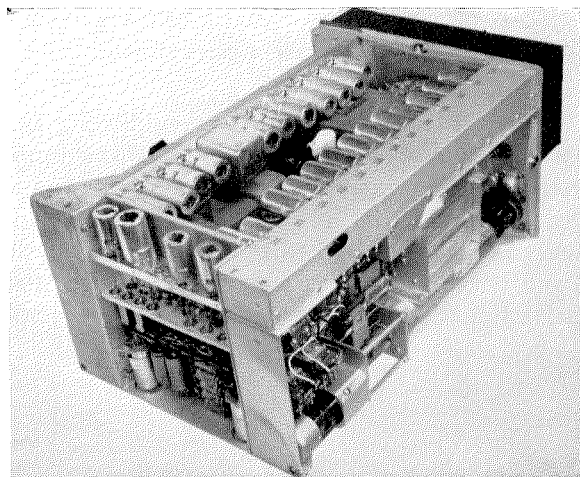

Figure 10—Rear view of main airborne unit.

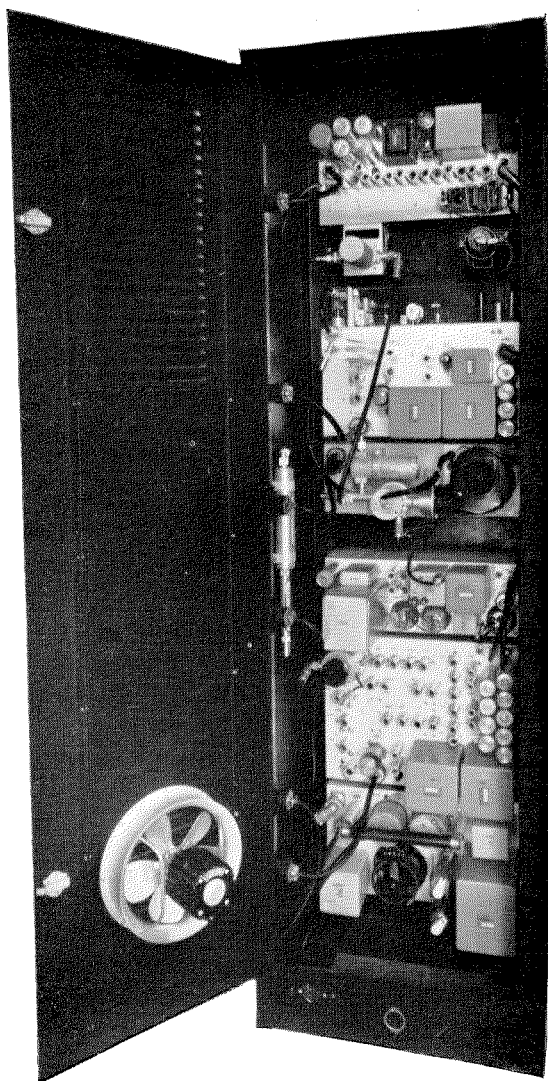

Figure 11—Rear view of ground beacon.

1960's. This system, while not employing the exact features developed by Federal Telecommunication Laboratories in that no provision is made for multiplexing other functions, does incorporate crystal control in the 1000-megacycle band with 2.5-megacycle channel spacings, and it is evident that the development of the equip-

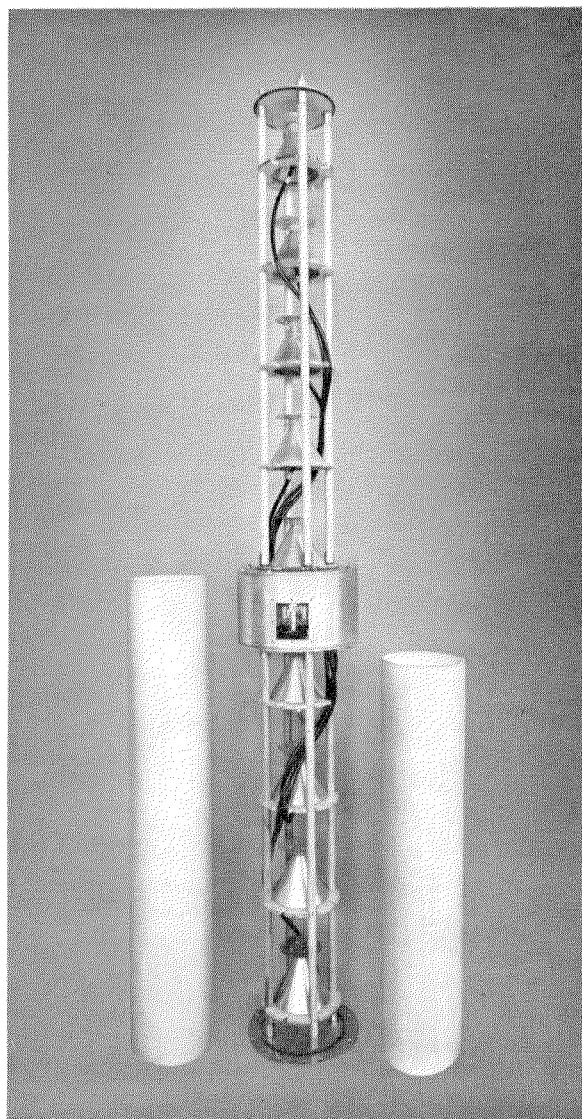

Figure 12—Ground-beacon antenna with cover removed.

ment described in this paper influenced greatly the final decisions of the Committee.

The major cost of this development was borne by the Air Materiel Command of the United States Air Force and Federal Telecommunication Laboratories, with a smaller contribution being made by the Civil Aeronautics Administration.

# Development of Toll Traffic in Switzerland, 1921–1947

By H. STOERI

*Standard Telephone et Radio S.A., Zurich, Switzerland*

**T**OLL TRAFFIC in Switzerland has increased steadily during the past 25 years. Technical improvements initiated during the past quarter of this century including the introduction of automatic toll operation,<sup>1</sup> have improved the service markedly and are important factors in this growth.

The rotary automatic toll system was designed jointly by engineers of Bell Telephone Manufacturing Company and Standard Telephone et Radio S.A. in close collaboration with the technical staff of the Swiss Telephone and Telegraph Administration.

## **1. Development of Toll-Line Plant After World War I**

As a result of the coal shortage that occurred during World War I, the Swiss government decided to introduce electric traction on the railroads. A traction voltage of 15,000 and a frequency of  $16\frac{2}{3}$  cycles per second were chosen, and as a consequence the elimination of open telephone lines running parallel to the railways became necessary.

In addition, statistics forecast a steady yearly increase in toll traffic, and so the administration decided to replace the open-wire lines by underground cables. As considerable distances were involved, it was decided in 1920 to use loaded cables with repeater stations. At that time, toll traffic was handled on a manual basis and the automatization of local exchanges was in an early stage, Zurich–Hottingen 1, the first rotary, having been cut over in 1917. The second rotary exchange, Geneva–Mont Blanc, was completed in 1924.

The modernization of the telephone plant and the additional traffic facilities offered by the toll cables, which were laid along the main traffic routes, resulted in a rapid and steady increase in

the number of subscribers as well as in an intensive development of traffic volume. A special study of this toll-traffic development has been made and is reported in the year books<sup>2</sup> of the Swiss Telephone and Telegraph Administration. Table 1 shows among other things the increase of toll traffic since 1921.

## **2. Toll-Line Efficiency With Manual Service**

Until 1929, toll traffic was handled on a manual basis. Taking 1925 as a first example, the following efficiency results were obtained. Neglecting Sundays and holidays and taking 300 business days per year, a toll line, if continually busy, could carry

$$\frac{60 \times 24 \times 300}{3} = 144,000$$

three-minute calls per year. During the year under consideration, 4891 toll lines were in operation, having a capacity of 704,304,000 three-minute toll calls. Since the 4891 lines actually handled only 49,618,000 calls, the efficiency on a *yearly basis* was

$$\frac{49,618,000}{704,304,000} = 0.0704$$

or 7.04 percent. The efficiency on a *busy-hour basis* for a manual toll line was at that time 70.8 percent. This figure is taken from an article<sup>3</sup> by E. Frey, manager of the Basle telephone district. This article also contains the data included in Table 2 on the average occupation of the lines per busy hour for the manual toll service between Basle and Zurich, using operators for both incoming and outgoing calls.

<sup>2</sup> *Annuaire 1922–1947 de l'Administration des Télégraphes et Téléphones Suisses.*

<sup>3</sup> E. Frey, "La Sélection Intervilles et le Service Rapide à Bâle," *Bulletin Technique* publié par l'Administration des Télégraphes et Téléphones Suisses, v. 6, pp. 202–223; December, 1933.

<sup>1</sup> G. Klingelfuss, "Zurich Automatic Tandem Toll Exchange," *Electrical Communication*, v. 25, pp. 113–120; June, 1948.

The efficiency during busy hours was, therefore,

$$42 \frac{29}{60} = 70.8 \text{ percent.}$$

The efficiency during a busy hour was, therefore,

$$45 \frac{33}{60} = 75.9 \text{ percent.}$$

### 3. Toll-Line Efficiency With Combined Line Recording

By 1930, the larger cities of Switzerland had been equipped for automatic local operation and, as an intermediate step toward automatic toll service, semiautomatic toll service was introduced in the form of long-distance dialing by operators. In this system, the operator at the originating end of the call dials the number of the distant subscriber and supervises the selection of the called line at the distant automatic exchange.

The average occupation of toll lines per busy hour for long-distance dialing is given<sup>3</sup> in Table 3.

The combined-line-recording system has proved very useful as a preparatory step to the introduction of fully automatic toll dialing in which the subscriber would dial the desired distant party without the aid of an operator. The line efficiency of operator toll dialing against manual operation was improved by approximately 5 percent, which is equivalent to an average increase in net income per toll line of one tariff unit per busy hour. The subscribers especially appreciated the no-delay service, in which they held the line while the operator dialed the number of the distant subscriber.

TABLE 1

TELEPHONE STATISTICS FOR SWITZERLAND, 1921-1947

Year	Inhabitants in 1000's	Connected Subscribers	Percentage Increase in Connected Subscribers	Telephones per Hundred Inhabitants	Taxed 3-Minute Units (Domestic) in 1000's	Toll Calls (Domestic, Average Duration 5 Minutes) in 1000's	Percentage Increase in Toll Calls	Taxed 3-Minute Units per Subscriber per Annum	Toll Lines	Yearly Calls per Toll Line	Yearly Busy Hours per Toll Line	Efficiency per Toll Line in Percent
1	2	3	4	5	6	7	8	9	10	11	12	13
1921	3,878	123,956	—	3.197	37,652	22,819	—	303.7	3,357	6,797	560.75	7.79
1922	3,875	129,875	4.775	3.351	40,763	24,705	8.263	313.9	3,645	6,761	557.78	7.76
1923	3,884	138,296	6.484	3.560	43,916	26,616	7.735	317.5	4,013	6,632	547.14	7.60
1924	3,896	146,036	5.597	3.748	47,444	28,754	8.033	324.9	4,552	6,317	521.15	7.24
1925	3,910	153,743	5.277	3.932	49,618	30,072	4.582	322.7	4,891	6,148	507.21	7.04
1926	3,933	161,678	5.161	4.111	52,312	31,704	5.429	323.6	5,297	5,985	493.76	6.86
1927	3,957	171,451	6.045	4.333	56,323	34,135	7.667	328.5	5,620	6,074	501.10	6.96
1928	3,990	185,257	8.052	4.643	62,001	37,576	10.081	334.7	6,015	6,247	515.38	7.16
1929	4,024	200,033	7.976	4.971	68,586	41,567	10.621	342.9	6,454	6,440	531.30	7.38
1930 <sup>1</sup>	4,051	215,135	7.549	5.310	74,303	45,032	8.335	345.4	7,141	6,306	520.24	7.22
1931	4,081	228,900	6.398	5.609	80,414	48,736	8.224	351.3	7,825	6,228	513.81	7.14
1932	4,104	240,213	8.748	5.852	82,534	50,021	2.636	343.6	8,728	5,731	472.81	6.57
1933 <sup>2</sup>	4,125	249,298	3.782	6.044	86,153	52,214	4.385	345.6	9,407	5,550	457.87	6.36
1934 <sup>3</sup>	4,144	260,895	4.652	6.296	88,639	53,721	2.885	339.7	9,852	5,453	449.87	6.25
1935	4,157	270,032	3.502	6.495	89,687	54,356	1.182	332.1	12,230	5,313	438.32	6.09
1936	4,167	276,046	2.227	6.624	90,175	54,652	0.544	326.7	10,576	5,168	426.36	5.92
1937	4,180	285,647	3.478	6.834	96,397	58,422	6.900	337.5	11,041	5,291	436.51	6.06
1938 <sup>4</sup>	4,192	295,782	3.548	7.056	101,305	61,397	5.192	342.5	11,484	5,346	441.04	6.13
1939	4,206	303,102	2.475	7.207	115,992	70,298	4.498	382.7	11,901	5,907	487.33	6.77
1940	4,226	310,182	2.336	7.339	124,181	75,261	2.060	398.2	12,256	6,141	506.63	7.04
1941	4,254	323,600	4.326	7.607	132,306	80,185	6.543	408.8	12,412	6,460	532.95	7.40
1942	4,283	342,376	5.802	7.993	146,436	88,749	10.680	427.7	12,871	6,895	568.84	7.90
1943	4,321	365,778	6.835	8.466	165,692	100,419	13.150	543.0	13,494	7,442	613.96	8.53
1944 <sup>5</sup>	4,362	389,338	6.441	8.927	188,320	114,133	13.657	483.7	13,990	8,158	673.03	9.35
1945	4,403	415,398	6.693	9.434	212,010	128,491	13.580	510.4	14,755	8,708	718.41	9.98
1946	4,466	446,543	7.498	9.999	233,294	141,390	10.039	522.4	15,385	9,190	758.17	10.53
1947	4,506	473,195	5.968	10.514	242,249	146,817	10.384	511.9	16,178	9,075	748.69	10.40

<sup>1</sup> Introduction of automatic toll lines (semiautomatic traffic).

<sup>2</sup> Introduction of fully automatic toll traffic between Zurich and Basle.

<sup>3</sup> Introduction of rapid toll service (Combined Line Recording).

<sup>4</sup> Introduction of fully automatic toll service (without tandem connections).

<sup>5</sup> Introduction of fully automatic toll services (with tandem connections).



**4. Toll-Line Efficiency with Fully Automatic Service**

In 1933, the first fully automatic toll service, in which the subscriber dials the number of the distant subscriber, was introduced between Basle and Zurich. The equipment proved most successful from the very beginning.

The average occupation of the fully automatic toll lines per busy hour is given<sup>3</sup> in Table 4.

TABLE 2

BUSY-HOUR MANUAL TOLL SERVICE BETWEEN BASLE AND ZURICH

	Minutes	Seconds	Percent
Time Not Charged to Subscribers			
Service Messages	3	4	
Calling	6	18	
Release	0	52	
Other Losses	1	59	
Total	12	13	20.4
Time Charged to Subscribers			
Duration of Calls	42	29	70.8
Unutilized Time	5	18	8.8
Total	60	00	100.0

TABLE 3

BUSY-HOUR SEMIAUTOMATIC OPERATOR TOLL DIALING BETWEEN BASLE AND ZURICH

	Minutes	Seconds	Percent
Time Not Charged to Subscriber			
Operator Dialing	2	46	
Subscriber Answering	4	03	
Release	0	42	
Other Losses	0	45	
Total	8	16	13.8
Time Charged to Subscribers			
Duration of Calls	45	33	75.9
Unutilized Time	6	11	10.3
Total	60	00	100.0

TABLE 4

BUSY-HOUR FULLY AUTOMATIC TOLL SERVICE BETWEEN BASLE AND ZURICH

	Minutes	Seconds	Percent
Time Not Charged to Subscriber			
Subscriber Dialing	1	40	
Subscriber Answering	3	57	
Release	0	00	
Other Losses	0	48	
Total	6	25	10.7
Time Charged to Subscriber			
Duration of Calls	48	42	81.2
Unutilized Time	4	53	8.1
Total	60	00	100.0

The efficiency during a busy hour was therefore,

$$\frac{48 \frac{42}{60}}{60} = 81.2 \text{ percent.}$$

If the three methods of toll switching are compared, it is evident that fully automatic switching proves to be the most efficient, the time lost being the minimum.

**5. Toll-Line Efficiency on a Yearly Basis**

Considering again the efficiency on a yearly basis, it will be seen from column 13 of Table 1 that the efficiency per toll line decreased from 1921 through 1936. This is evident from the figures selected for Table 5 from columns 3, 6, 10, and 13 of Table 1.

From 1921 to 1936, toll traffic was predominantly handled on a manual basis and required a great number of toll lines spread inefficiently over the country. Consequently, the yearly

TABLE 5

SUBSCRIBER AND TOLL LINES AND TOLL CALLS FOR 1921, 1936, AND 1947

	1921	1936	1947	Gain or Loss 1921-1936		Gain 1936-1947		Gain
				Number	Percent	Number	Percent	1936-1947 1921-1936 %
Subscriber Lines	123,956	276,046	473,195	152,090	123	197,149	71	130
Toll Lines	3,357	10,576	16,178	7,219	215	5,602	53	78
3-Minute Toll Calls (thousands)	37,652	90,175	242,249	52,523	142	152,074	169	290
Toll Calls per Toll Line	11,216	8,527	14,975	-2,689	-24	6,448	76	—

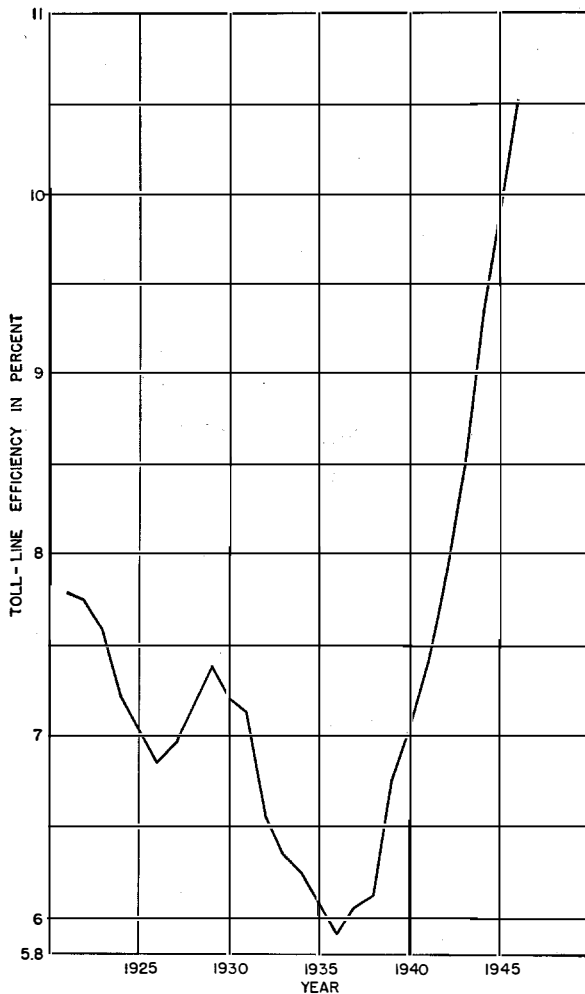

Figure 1—Toll-line efficiency on a yearly basis.

efficiency per toll line dropped from 7.79 in 1921 to 5.92 percent in 1936.

For the period from 1936 to 1947, the yearly efficiency per toll line almost doubled, going from 5.92 percent to 10.40 percent.

It was in this span of years that automatic toll service was introduced.

It is interesting to note that whereas the 1936–1947 period showed an increase in subscriber lines of 130 percent over the gain for 1921–1936, and of 290 percent for toll calls, the increase in toll lines during the later period was only 78 percent of that from 1921 to 1936. This fact illustrates clearly the improvement in efficiency of toll lines that is one of the great advantages of fully automatic toll service.

Figure 1 illustrates the variation in efficiency

of toll lines as a function of years. The sharp decrease from 1929 to 1936 may be explained by the rather large increase in toll lines (64 percent) compared to the small increase in subscribers' lines (38 percent) and, in part, to the years of economic depression, 1930 to 1934.

Curve 1 of Figure 2 represents the development of subscribers' lines between 1921 and 1947, the total number of taxed 3-minute calls is illustrated by curve 2, and the total number of domestic toll calls are given in curve 3. Curve 2 clearly shows the rapid increase in domestic toll traffic since the introduction of fully automatic toll service.

This is more easily seen from Figure 3, where curve 2 illustrates the increase of toll traffic since 1939, when fully automatic toll switching for terminal traffic (without tandem connections) was generally introduced in Switzerland; tandem switching became effective in 1944. The number

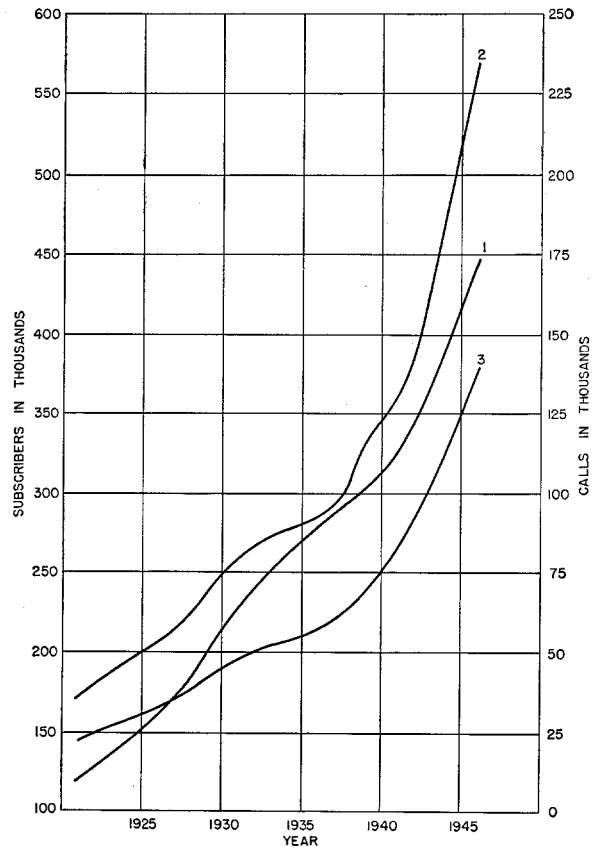
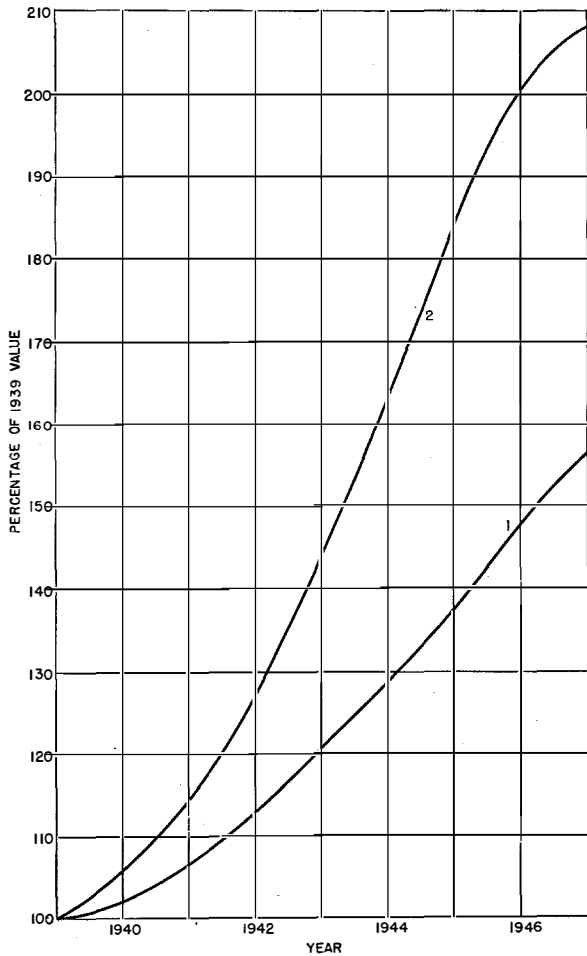

Figure 2—Curve 1 is for subscribers lines. Curve 2 gives the total number of taxed 3-minute units. Curve 3 is for domestic toll calls.



in toll traffic. Thus, traffic was concentrated on the lines available and produced a high line efficiency. The decline in efficiency from 1946 is due to the fact that the toll lines are no longer overloaded and, further, to a drop in the yearly number of taxed 3-minute toll calls per subscriber line. Another reason is that the percentage increase in subscriber lines in 1946 and in 1947 (7.5 and 6.0 percent, respectively) was in inverse proportion to the planned and effected increase in toll lines (4.2 and 5.1 percent, respectively).

The reduction in the number of yearly taxed 3-minute toll calls per subscriber line may also result partially from the transition from war to peace and the return to more nearly normal business conditions.

No increase in telephone rates occurred during the last 25 years, whereas the earnings of the population and the cost-of-living indexes have increased by at least 75 percent during this time.

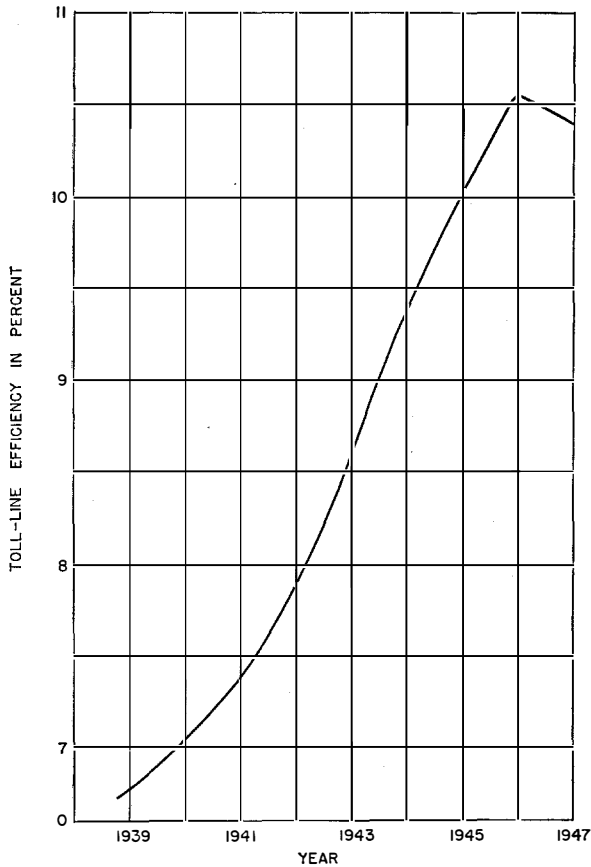

Figure 4—Toll-line-efficiency variation between the years 1939 and 1947.

Figure 3—Curve 1 gives the variation in subscriber lines and curve 2 of toll connections based on 1939 figures as 100 percent.

of subscriber lines increased between 1939 and 1947 by approximately 57 percent, whereas the number of toll connections in 1939 was exceeded in 1947 by 108 percent.

Other interesting facts are evident from column 12 of Table 1, which gives the average number of hours per year during which a toll line is occupied. Assuming 300 business days per year, the number of hours a toll line can be occupied each year would be  $24 \times 300 = 7200$  hours. Knowing the number of toll lines and of taxed units and the duration of toll calls, the efficiency can be determined for each line and may be found in Figure 4.

Due to the shortage of raw materials during World War II, the Swiss toll plant could not be expanded to the extent justified by the increase

The efficiency per toll line having increased from 7.79 percent in 1921 to 10.53 percent in 1946 indicated additional utilization of each toll line by 35 percent.

The telephone development in Switzerland rose from 3.2 per hundred population in 1921 to 10.5 in 1947. For a growth in population of 16 percent in this interval of time, the number of subscribers increased by 280 percent and the number of taxed 3-minute toll calls per subscriber by 68 percent.

The above recapitulation of traffic information contained in the various administration publications noted and the several factors cited as contributing to traffic changes indicate clearly that the development of toll traffic in Switzerland has been both sound and favorable. There is no doubt that the fully automatic toll service offered to subscribers is mainly responsible for this remarkably large augmentation of toll traffic as well as for the improved efficiency of toll-line plant.

---

### *Recent Telecommunication Development*

#### **Stockholm-Göteborg Coaxial Telephone Cable**

**T**HE FIRST MODERN coaxial cable conforming to the specifications of the Comité Consultatif International Téléphonique to be laid on the European continent was placed in service between Stockholm and Norrköping, Sweden, just twenty-five years after these two cities were joined by the first long-distance repeatered telephone cable in Europe. Both cables were designed, manufactured, and installed by Standard Telephones and Cables, Limited, of London, England.

The new high-frequency coaxial cable runs from Stockholm, through Norrköping, to Göteborg, a distance of nearly 300 miles. To reduce cable costs, it was laid in a straight line across

country, not paralleling existing roads, and includes several submarine sections.

There are four coaxial tubes and five quads in the cable. With repeaters at approximately 6-mile intervals, each pair of tubes is capable of providing for 960 telephone circuits. Almost all of the repeaters are unattended and receive their operating power over the cable.

The Stockholm-Norrköping cable will provide 180 new trunk circuits immediately with the terminal equipment recently installed by Standard Telephones and Cables, Limited. A new type of construction reduces substantially the space occupied by the terminal equipment and maintenance work is facilitated by having component panels jack into position in the bays.

# Antenna Impedance Measurement by Reflection Method\*

By EDWIN ISTVÁNFFY

*Standard Electric Company, Limited, Budapest, Hungary*

**T**WO METHODS of measuring the impedance of radiators are described. They are based on measurement of the power reflected by the radiators. These methods are particularly useful for finding the radiation resistance of thick half-wave dipoles.

• • •

Numerous papers published during the last few years relating to antenna-impedance calculations and measurements are concerned with determining the radiation resistance of antennas in which the radius of the antenna conductor cannot be neglected. Although recently published new methods of calculation give better approximations, they are not adequate for a dipole in which  $\Omega = 2 \log_n (2l/a) \leq 10$ , where  $2l$  and  $a$  are the length and the radius of the dipole, respectively, and  $\Omega$  is an often-used parameter determined by the length-to-thickness ratio of the conductor.

Impedance measurements commonly introduce discontinuities through coupling the dipole to the measuring equipment. These difficulties may be avoided by placing the antenna in the beam of a directional transmitter-receiver—like a radar target—and measuring the power reflected to the receiver.

The amplitude of the received signal depends on the *reflected power*, and the target distance for maximum reflected power depends on the *phase of the antenna impedance*.

By varying the length of a dipole, while retaining a constant thickness, the resonant length for a given wavelength may be found from the changes in reflected power.

Another check is to compare dipoles of different thicknesses, whose resonant lengths have been determined. If their resonant lengths correspond exactly, maximum reflection must occur at exactly the same target distances.

When the resonant lengths of dipoles having different length-to-thickness ratios are determined, a comparison of their reflective properties from the same target distance permits the ratio of their radiation resistances to be calculated.

If the field strength produced by the transmitter at the dipole is  $E_t$ , the induced voltage in the dipole is  $V = E_t h_{eff}$ , where  $h_{eff}$  is the effective length of the dipole. The impedance of a dipole adjusted to its resonant length is equal to its radiation resistance  $R_r$ . Thus, the reflected power is

$$P_r = \frac{E_t^2 h_{eff}^2}{R_r} \quad (1)$$

and the ratio of the reflected powers for two dipoles is

$$\frac{P_r''}{P_r'} = \left( \frac{h_{eff}''}{h_{eff}'} \right)^2 \frac{R_r'}{R_r''} \quad (2)$$

The directional properties of resonant-length dipoles of different thicknesses show only small variations and, for small differences in length,

$$\frac{h_{eff}''}{h_{eff}'} = \frac{l''}{l'} \quad (3)$$

where  $l''/l'$  is the ratio of the resonant lengths of the two dipoles. The ratio of resistances, as derived from (2) and (3), is

$$\frac{R_r''}{R_r'} = \frac{P_r'}{P_r''} \left( \frac{l''}{l'} \right)^2 \quad (4)$$

Although this is a comparative method, the absolute value of the radiation resistances may also be found, provided the value of one of the tested dipoles is known.

Another method of determining radiation resistance is based on measured phase-angle data as a function of dipole length in electrical degrees. This method is not comparative. Using an impedance circle diagram, it is possible to determine the radiation resistance by plotting one part of the impedance locus curve.

\* Reprinted from *Proceedings of the I.R.E.*, v. 37, pp. 604-608; June, 1949.

### 1. Setup and Technique

The measurements were carried out on an athletic field. Horizontally polarized waves were used. Figure 1 shows the equipment as set up for making measurements. On the table are the transmitting and receiving parabolic reflectors, which are of similar design. In front of the reflectors is a wooden track 2.5 meters (8.2 feet) long and 0.5 meter (1.6 feet) high, on which a little wooden carriage, that carries the dipole under test, can be moved by strings from behind the reflectors. The focal line of the reflectors was 1.5 meters (4.9 feet) above the ground and the axis of the dipole under test was set in each case to this height. An indicator fixed to the side of the carriage and a scale on the track, marked at every half centimeter, enabled the target distance to be determined within an accuracy of about 1 millimeter (0.04 inch).

A battery-operated 955 acorn triode produced an output power of about 0.1 watt at a wavelength of 55.2 centimeters (540 megacycles per second). The transmitting dipole and its oscilla-

The receiving dipoles and crystal rectifier were mounted in the other reflector, from which two wires were brought out through a radio-frequency filter to a meter. The detector was a silicon crystal with gold electrode and operated as a square-law rectifier.

Initially, a heavier carriage was used, but, even without a dipole, it caused significant changes in the meter deflection as it was moved. The structure of the carriage was gradually reduced to that shown in Figure 1. With an initial deflection of 40 divisions on the receiving meter caused by direct pickup from the transmitter, a change of about 0.5 division or less resulted from moving the carriage along the track.

Tests made with dipole-supporting structures showed that, for thin antennas, the use of dielectric materials near the dipoles, especially at the ends, tended to decrease the resonant length and impair the response at resonance. To avoid these effects, the holder, shown in Figure 2, was placed at the center of the dipole. The dipole is lying on two 1-millimeter (0.04-inch) phenol-fiber plates 10 millimeters (0.39-inch) apart, and is held in position by a small rubber strip.

Some of the transmitted power picked up directly by the receiver and a relatively small amount reflected by the ground and distant objects produce an initial reading on the meter. Some efforts were made at first to compensate for these effects, but later it was obvious that this was unnecessary. The direct pickup causes a steady field at the receiver, to which the

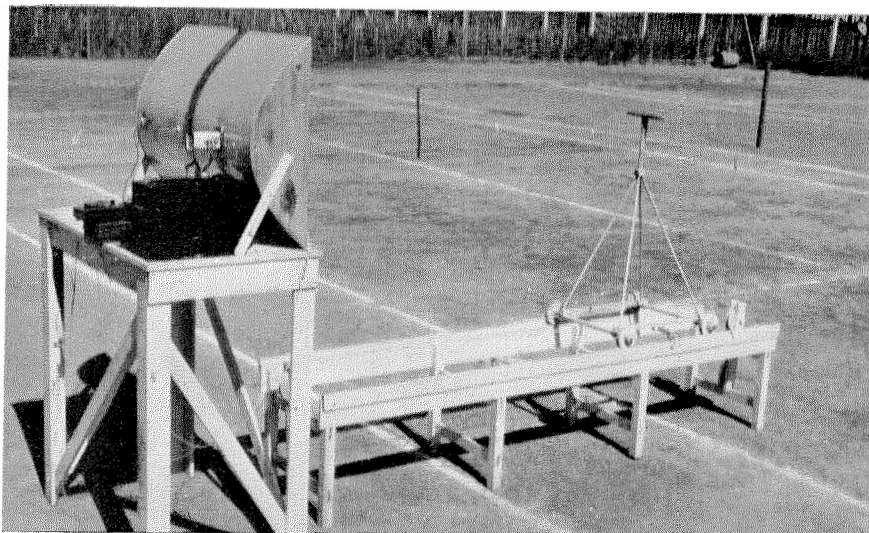

Figure 1—The setup of equipment for making reflection measurements.

tor were placed in the focus of one of the parabolic reflectors, the apertures of which measured 69 by 50 centimeters (27 by 20 inches). For reducing the direct pickup by the receiver, the focus was 7 centimeters (2.75 inches) inside the aperture. The power gain of the reflector was 9.

reflected field from the target dipole is added and, when the target is moved, the phase of the reflected wave rotates, causing phase additions and oppositions with the steady field and alternate maximum and minimum deflections of the meter.

If the distance to the dipole target is large compared to that between the transmitting and receiving dipoles, the distance between adjacent maxima or minima is half the free-space wavelength. It may be shown that, with square-law

**2. Measurements**

Five series of dipoles were tested; their diameters being 0.14, 0.48, 3, 13.6, and 40 millimeters (0.006, 0.019, 0.118, 0.535, and 1.575 inches). The first two sizes were of bare copper wire, and a series of different lengths ranging from 230 to 280 millimeters (9 to 11 inches) were prepared. The 3-millimeter dipoles were brass rods and a similar series were made. The dipoles of 13.6- and 40-millimeter diameters were brass tubes with 1-millimeter (0.04 inch) wall thickness and were adjustable in length. Both could be used with closed and open ends.

First, the field strengths were measured along the track of the target. For this purpose, a tuned dipole fitted with a thermocouple was placed on the holder and the readings on the linear scale of the meter were recorded for different distances. The plotted field power curve, which is proportional to the square of the field strength, is shown in Figure 3. At a distance of 2.2 meters, there is a flat minimum caused by reflections from the earth. From about 2 to 2.4 meters, the field power changes very little and, therefore, this range was considered to be most suitable for measurements.

Figure 4 shows the maxima and minima of the receiver meter deflections when moving a 3-millimeter dipole of resonant length along the track. A deflection of 41 divisions was obtained in the absence of a dipole. The square-root values of the readings are proportional to the field strengths.

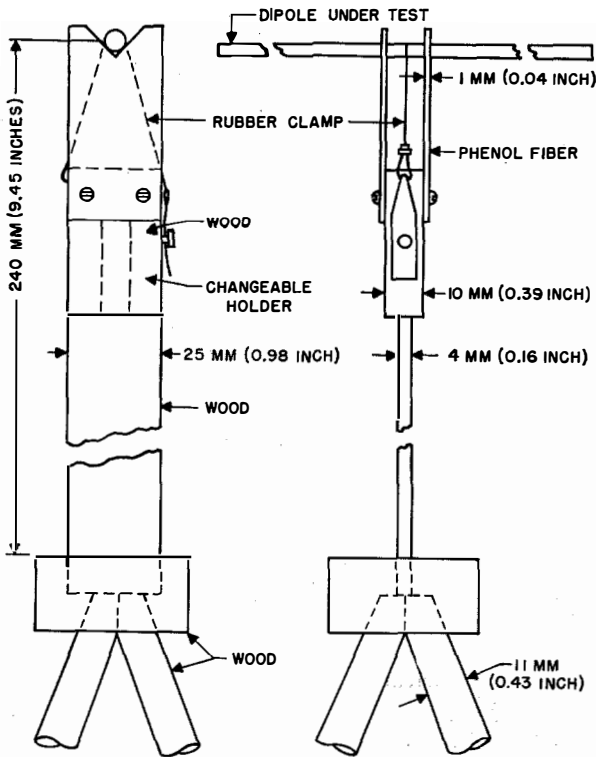

Figure 2—The dipole support is changeable and is mounted at the top of the carriage.

detection, if the reflecting powers of two dipoles being tested are unequal, the difference in the meter deflections increases as the steady field becomes stronger. Further, there is an improvement in the accuracy of positioning the dipole for maximum deflection of the meter with increasing steady field, and the target-distance measurements make possible the calculation of the phase of the impedance.

If a dipole is made longer than its resonant length so that the current lags 45 degrees behind the voltage, this will cause a time lag at the receiver that may be compensated for by moving the target 1/16 wavelength nearer to the transmitter-receiver. In this way, if the resonant length is known, the phase of the impedance can be determined.

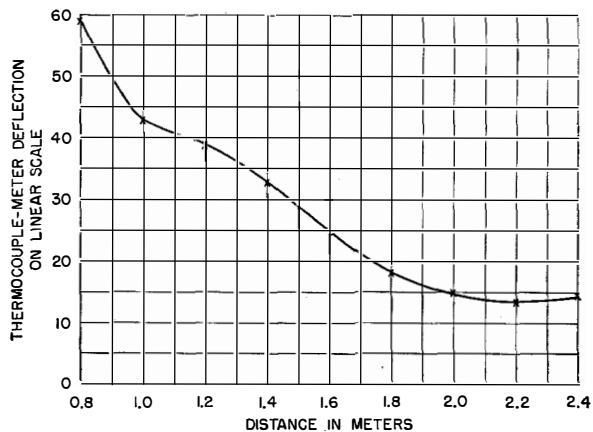

Figure 3—The measured field-power curve along the track of the target. From about 2.0 to 2.4 meters, the field power is approximately constant and this range is most suitable for the measurements.

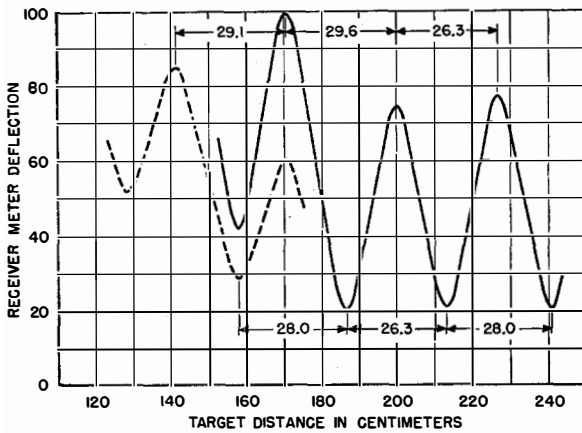

Figure 4—Maximum and minimum deflections when moving a dipole along the track. The dotted curve is for 120 volts and the solid curve for 150 volts on the plate of the oscillating tube.

From Figure 4, it is evident that the distances between adjacent maxima and minima show some irregularities. The average value, however, calculated from the sum of the last two maxima and minima, gives accurately the free-space half-wavelength used (276 millimeters).

Figure 5 shows curves of the measured maximum deflections plotted against dipole lengths for different dipole thicknesses. The thinnest dipole gave the sharpest resonance curve, while the curve of the 40-millimeter dipole is so flat that the resonant length can hardly be determined from these measurements.

The target distances are plotted against dipole lengths in Figure 6 for the five different diameters. On the coordinate scale, only target

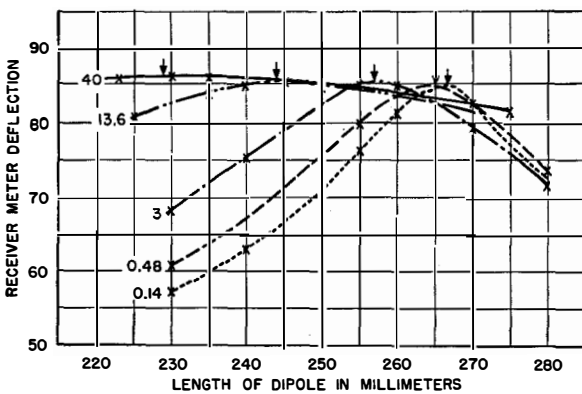

Figure 5—Measured maximum deflections for dipoles of different lengths and diameters. The figures identifying the curves are the diameters of the dipoles in millimeters.

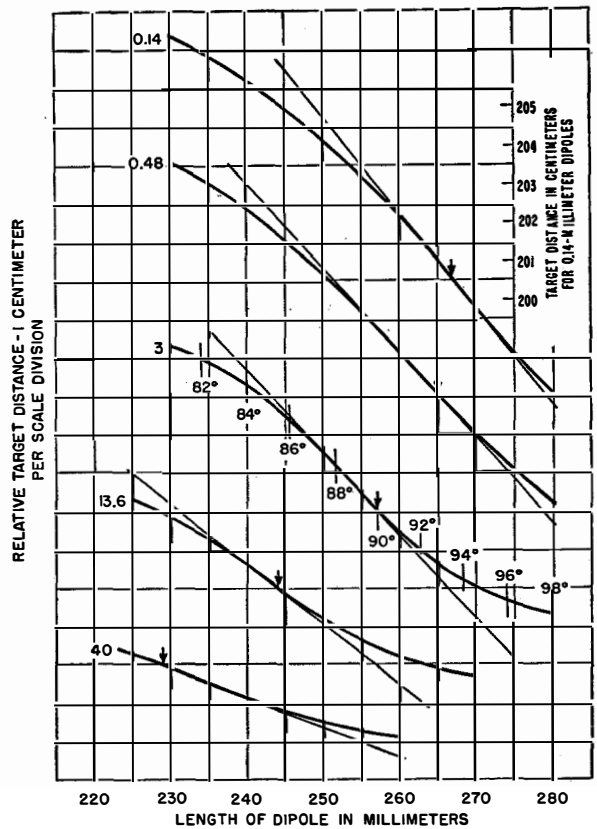

Figure 6—The measured changes of target distances for dipoles of different lengths. The resonant lengths are marked with arrows. Actual distances are given for only one dipole thickness, 0.14 millimeter, the remaining curves being plotted against relative distances.

distances for the 0.14-millimeter dipoles are shown. For the other curves, only relative changes in distance are needed. The resonant lengths are marked with arrows. The inflection tangents are also drawn, giving a rough check of the correctness of the resonant lengths. As may be seen, the angle of the tangents to the horizontal will be smaller with increasing dipole thickness.

### 3. Comparison of Reflected Power and Calculation of Radiation Resistance

To produce the highest useful deflection of the receiver meter, measurements were made at a target distance of 1.7 meters (67 inches) on the previously checked five resonant-length dipoles of different thicknesses.

The results are given in Table 1. For the 0.48-, 3-, and 13.6-millimeter dipoles, the measured



target distances are equal, which is a statistical proof of the correctness of the lengths. For the 40-millimeter dipole, the small difference in target distance was probably caused by the nonuniform current distribution around the surface of the dipole and for that reason no correction was made.

TABLE 1

Diameter of dipole in millimeters	0.48	3	13.6*	40*
Diameter of dipole in inches	0.019	0.118	0.535	1.575
Resonant length in millimeters	265	257	244	229
Target distance in centimeters	171.4	171.4	171.4	171.6
Dipole length				
Free-space half wavelength	0.96	0.931	0.885	0.83
Maximum receiver meter deflection	96.5	97.5	98	98.5
Corrected meter deflection, without steady field	11.7	12.0	12.25	12.4
Ratio of resistances	1	0.935	0.828	0.72
Radiation resistance based on 63 ohms for 3-millimeter dipole	67.5	63	55.8	48.5

\*With closed ends.

method dealt with in Section 4. The 3-millimeter dipole was chosen as its radiation resistance of 63 ohms was one of the most reliable values found, being only slightly influenced by the limitations of the measurement methods. The radiation resistances for the other dipoles were calculated from this value and the ratios, and are given in the last line of the table.

#### 4. Calculation of Antenna Impedance from Phase Measurements

To calculate antenna impedance from phase measurements, an impedance circle diagram was prepared in chart units<sup>1</sup> as shown in Figure 7. This represents an enlargement of only a small part of the usual diagram. The horizontal distances from the origin are equal to the resistive components, and the vertical distances to the reactive components of the impedances in chart units, i.e., the unit of the chart is the characteristic impedance of the line. The constant- $\phi$  circles correspond to the lengths of the line in electrical degrees;  $\phi = 90$  degrees represents the resonant length of a dipole.

<sup>1</sup> Massachusetts Institute of Technology, Radar School Staff, "Principles of Radar," McGraw-Hill Book Co., New York, New York, 1946; chapter 8, p. 58.

For the 0.14-millimeter dipole, the somewhat uncertain results of comparison were probably caused by the fact that a straight position of this very thin wire could not be secured. For this reason, it is not included in Table 1.

For calculating the ratio of the reflected powers, the effect of the steady field must be eliminated. The corrected values were calculated by

$$\alpha_{cor} = (\alpha^{\frac{1}{2}} - \alpha_0^{\frac{1}{2}})^2, \quad (5)$$

in which  $\alpha_0$  was 41 divisions, the value for the steady field. These corrected values are also given in Table 1.

The loss resistance of the 0.48-millimeter dipole must not be neglected in these comparisons. Calculations showed that the reflected power decreases by about 2 percent as a result of the loss resistance. Therefore, the ratios of radiation resistance calculated with (4) must be multiplied by 1.02. These ratios are included in Table 1.

To obtain numerical values of radiation resistance, use was made of one of the values of radiation resistance, determined by the phase

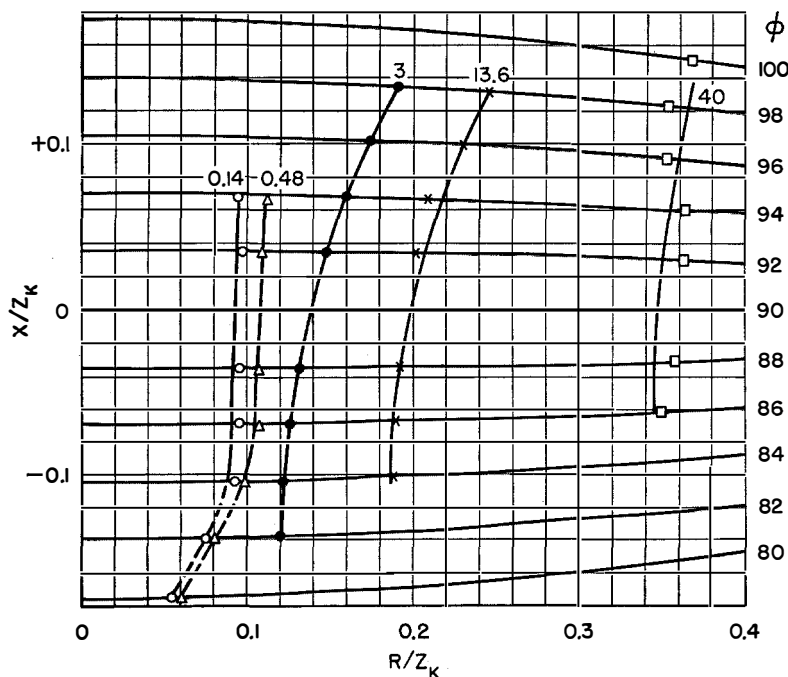

Figure 7—Impedance locus curves plotted on an impedance circle diagram in chart units.

As an example, let us take the diagram of the 3-millimeter dipole. In Figure 6, the resonant length was 257 millimeters, which is equal to 90 electrical degrees. Thus 1 degree corresponds to 2.8 millimeters change in length. Figure 6 gives values from 82 to 98 degrees for this dipole. The vertical distances, measured from the target distance of the resonant-length dipole, are proportional to the phase angles of the impedances. Half the free-space wavelength, i.e., 276 millimeters, corresponds to 360 degrees, thus 1 millimeter on the vertical scale is equal to 1.3 degrees of phase angle. For  $\phi=96$  degrees,  $\Delta D = -23$  millimeters, which corresponds to  $23 \times 1.3 = +30$  degrees of phase angle. If a line is drawn with a slope of 30 degrees from the origin, then the intersection with the  $\phi=96$  degree circle will give one point of the impedance spiral diagram.

A number of points are marked on Figure 7 for dipoles of different thicknesses. The irregularities in some points indicate the presence of some disturbing effects, which seem to be greatest for the thinnest dipoles and when they are tuned off resonance.

The radiation resistance at resonant length is obtained at the intersection of the impedance locus curve and the  $X=0$  abscissa. It is customary to call this reading the "standing-wave ratio." Multiplying this value by the calculated characteristic impedance of the resonant-length dipole gives radiation resistance at the resonant length. The results are given in Table 2, where the calculated values of the characteristic impedance and the parameter  $\Omega$  are also tabulated. The radiation resistances of the first two dipoles could not be determined with certainty.

Comparing these values with those of Table 1, it may be seen that the agreement is fair enough, although two quite different methods have been

used. The somewhat greater values for the thickest dipoles, as measured by the amplitude method, could probably be explained by the small change in directional characteristics of the dipoles of shorter length.

Some data for dipoles of varying length-to-thickness ratio, calculated by different theories and also measured by the described methods, are given in Table 3.

TABLE 3<sup>2,3</sup>

$\Omega = 2 \log_n (2l/a)$	16.2	13.8	10.2	7.15	4.87
Hallen-Bowkamp, 1 <sup>st</sup> order	63.1	61.54	58	—	—
Hallen-Bowkamp, 2 <sup>nd</sup> order	68.7	66.5	60.4	—	—
Gray, modified, 1 <sup>st</sup> , 2 <sup>nd</sup> order	69.7	69.2	67.3	—	—
King-Middleton, 1 <sup>st</sup> order	69.2	68.1	65	—	—
King-Middleton, 2 <sup>nd</sup> order	70.85	70.82	70.77	—	—
Schelkunoff	66.7	65.2	61.4	—	—
Measurements					
Amplitude	—	67.5	63	55.8	48.5
Phase	—	—	63	53.9	45.5

For  $\Omega=10.2$ , best agreement with measured values is obtained with calculations based on the Schelkunoff and King-Middleton first-order formulas.

For the same dipole, some other measured and calculated values may be compared. For the free-space half-wave dipole, the measured impedance values according to Figure 7 are:  $R=82$  ohms,  $X=53$  ohms, and phase angle = 32.5 degrees. According to Schelkunoff, these values are:  $R=75$  ohms,  $X=45$  ohms, and phase angle = 31 degrees. The King-Middleton second-order gives:  $R=88$  ohms,  $X=42.5$  ohms, and phase angle = 25.8 degrees. The measured resonant length of this dipole was less by 0.095 radian than  $\pi/2$ ,

<sup>2</sup> D. Middleton and R. King, "The Thin Cylindrical Antenna: A Comparison of Theories," *Journal of Applied Physics*, v. 17, pp. 273-284; April, 1946.

<sup>3</sup> S. A. Schelkunoff, "Electromagnetic Waves," 4th edition, D. Van Nostrand Company, New York, New York, October, 1945; p. 464.

TABLE 2

Diameter of dipole in millimeters	0.14	0.48	3	13.6	40
Diameter of dipole in inches	0.006	0.019	0.118	0.535	1.575
$\Omega = 2 \log_n (2l/a)$	16.2	13.8	10.2	7.15	4.87
Characteristic impedance of resonant-length dipole in $\Omega, Z_k$	830	678	456	269	130
Standing-wave ratio from Fig. 7	0.092	0.107	0.138	0.2	0.35
Radiation resistances at resonant lengths	76*	72.5*	63	53.9	45.5
Radiation resistances at resonant lengths without loss	73.5*	71.8*	63	53.9	45.5

\* The position of these curves was somewhat uncertain.

if  $\pi/2$  corresponds to the free-space half-wavelength. According to the Schelkunoff and King-Middleton second-order calculations, this value was 0.094 radian.

For  $\Omega < 10$ , unfortunately, no data were available for comparison.

Measurements made with open-ended tubes for the 13.6- and the 40-millimeter dipoles showed no practical differences in resonant lengths and in reflected powers.

#### 4.1 LIMITATIONS

The slight effect of the carriage and probable small changes in earth reflections when moving the target may cause some irregularities in the steady field and in the meter deflections, especially for thin and detuned dipoles. This was

substantiated by irregularities observed between adjacent maxima and minima when moving the target. Deviations in the impedance locus curves may result. Further, difficulties in obtaining accurately straight positions of thin wires made the equipment most suitable for determining the impedances of relatively thick dipoles. For the thickest dipoles, changes in target distance versus dipole length were small, and the accuracy of setting limited the results. With the amplitude method of comparing reflected powers, the effect of these factors was reduced.

During measurements, the anode voltage was maintained at  $160 \pm 0.2$  volts, and the crystal detector proved to be very stable. The accuracy of the wavelength measurements was about  $\pm 1$  millimeter.

# Experimental Ultra-High-Frequency Multiplex Broadcasting System \*

By A. G. KANDOIAN and A. M. LEVINE

*Federal Telecommunication Laboratories, Incorporated, Nutley, New Jersey*

**A** DEFINITE INDICATION that the need for broadcast facilities in the near future will far exceed the available channels is recognized. A feasible expansion appears to be in the ultra-high-frequency spectrum.

To produce the maximum number of channels at ultra-high frequencies, a multiplex system of broadcasting has many advantages: A large number of broadcast programs are transmitted at an assigned frequency from a single location and using only one transmitter and antenna system. Effective use is thus made of an optimum transmitting site, a considerable advantage at very- and ultra-high frequencies where line-of-sight limitation of transmission exists.

An experimental eight-channel high-fidelity multiplex broadcasting system has been developed and operated during the past year. Multiplex operation is achieved by time-sharing pulse-time modulation. The operating frequency is 930 megacycles per second.

The discussion includes a description and operating characteristics of the major components, including modulator, transmitter-antenna system, and receiver.

. . .

Even with the opening of the new frequency-modulation broadcast band, there is definite indication that the need for broadcast facilities will, in the not-distant future, far exceed the available channels. To relieve the situation, it seems safe to assume that further expansion of the broadcast spectrum will become necessary. Such further expansion appears feasible only at ultra-high frequencies, or beyond.

The development here reported was, therefore, directed to the determination of how broadcasting could best be achieved at ultra-high frequencies. The actual frequency used was 930 megacycles

per second, within the 920 to 940-megacycle range assigned by the Federal Communications Commission for experimental broadcasting. The system developed, however, could be reproduced anywhere in the ultra- or even the super-high-frequency range.

It should be emphasized that this development is not intended to replace either the present amplitude- or frequency-modulation broadcasting facilities, but rather to supplement both when there is demand for more channels.

To produce the maximum number of useful broadcast channels at ultra-high frequencies, it appears more desirable and economical to broadcast in multiplex with a large number of channels per assigned frequency, rather than one frequency assignment per broadcast channel, as is conventional at lower frequencies. This, of course, does not reduce bandwidth requirements per channel, but it does reduce or eliminate wasteful "guard" frequency separation between adjacent stations to avoid the damaging effects of possible carrier drift. In addition, there is a more potent and fundamental reason for choosing a multiplex form of broadcasting at ultra-high frequencies, rather than the conventional simplex system used at lower frequencies. This has to do with the radiation and propagation characteristics of these waves.

At ultra-high frequencies, a relatively high antenna power gain (concentration of radiated energy in desired directions) is easily and economically achieved. Since propagation is essentially limited to line of sight, tall building tops and other elevated spots offer the best locations for transmitting antennas. In most localities, there are only one or two such effective transmitting sites, and each will accommodate about one transmitter. In a multiplex broadcasting system, a substantial number of transmissions share each optimum site. This advantage is even more pronounced from the receiving standpoint, especially for television.

\* Reprinted from *Proceedings of the I.R.E.*, v. 37, pp. 694-701; June, 1949. Presented at Institute of Radio Engineers National Convention, New York, New York, March 5, 1947.

For each transmitting station, there are a multitude of receiving sites. At ultra-high frequencies, antenna gain can be obtained cheaply, even for reception. A very small and simple array, a dish, or a horn will provide a large amount of power gain and directivity. When, because of a large number of transmitting sites, the programs are received from many directions, a single highly directive receiving antenna is not usable unless fitted with an expensive steering mechanism. With a multiplex broadcasting system, the same receiving-antenna orientation not only will give optimum response on all channels but may be adjusted to reduce interfering signals and noise. These important factors provide substantial reasons for using a multiplex form of broadcasting in the ultra-high-frequency spectrum.

A multiplex system, for broadcasting as well as for telephony and general communication applications, may take many forms. Amplitude modulation of several mutually interrelated subcarriers, finally modulating the ultra-high-frequency carrier, would be one possibility. Fre-

quency modulation of subcarriers, which in turn modulate the final carrier frequency, might also be used. Pulse systems involving amplitude, time, width, etc., modulation also are important possibilities. Various combinations of the above might offer even greater advantages than any single type of modulation.

In view of recent advances in pulse techniques and, particularly, since high-power pulse-type radio-frequency generators (magnetrons and some triodes) are available for most, or all, of the ultra-high-frequency band, a pulse system of modulation with a time-sharing form of multiplexing was agreed on for the first development of this system.<sup>1</sup>

### 1. Pulse-Time-Modulation Multiplex System

To demonstrate as effectively as possible the versatility and advantages of the system, it was decided to multiplex eight broadcast-quality channels. For each channel, 24,000 pulses per second are used to sample each program. This rate corresponds approximately to three times the highest audio frequency to be transmitted. In addition to the channel pulses, which are varied in timing to provide the necessary modulation for each channel, a fixed marker pulse is also transmitted at a 24-kilocycle rate, one for each train of eight pulses corresponding to the eight channels. This marker pulse provides the necessary reference point for demodulation at the receiver.

Figure 1 shows a block diagram of the experimental system recently completed and demonstrated. Each of the eight audio-frequency signals is used to vary the timing of pulses approximately 0.5-microsecond wide. The resulting video-frequency signal is then used to pulse a radio-frequency oscillator, in much the same manner as in radar applications.

For reception, a conventional local oscillator and mixer produce the intermediate-frequency signal voltage; this is amplified and detected to provide the video-frequency signal, which is then used to select channels and demodulate each program. Details of the various components making up the complete system are given in the following sections.

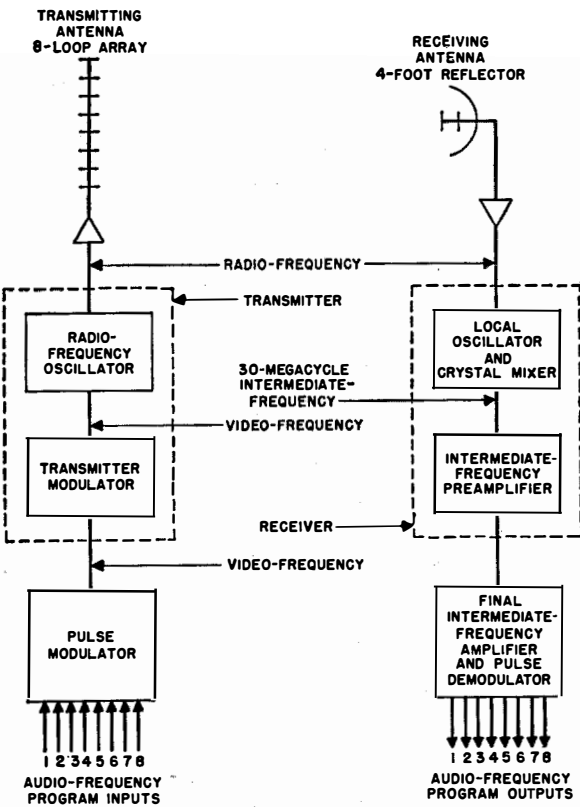

Figure 1—Block diagram of the multiplex broadcasting system.

<sup>1</sup>D. D. Grieg, "Multiplex Broadcasting," *Electrical Communication*, v. 23, pp. 19-26; March, 1946.

The transmitting station during all tests on this system was located on the roof of 67 Broad Street, approximately 485 feet above ground in downtown New York City.

Figure 2 shows a view of the experimental transmitter equipment exclusive of the transmitter modulator and radio-frequency generator; these were located close to the antenna. Figure 3 shows the experimental omnidirectional transmitting antenna.

Most of the receiving tests were made at the Nutley laboratories, 11 miles away, where the receiving antenna was located on a roof, approximately 25 feet above the surrounding terrain. Comparable receiving tests have also been made in the surrounding countryside with portable equipment installed in a station wagon.

Typical services carried simultaneously during various tests and demonstrations included rebroadcasting of standard amplitude- and frequency-modulation programs and operation of stock ticker (Dow Jones), teletype (Mackay Radio), facsimile (New York Times), and photo transmission. The receiver, shown in Figure 4, is quite conventional in appearance. It differs in operation from more conventional receivers only in that no radio-frequency tuning is required. The channel selection is done entirely at video frequencies by timing circuits.

Where more than one program is desired simultaneously, for example, in separate rooms of the same building, it is not necessary to duplicate the complete receiver but only a portion of the video-frequency system and

an audio-frequency circuit for each service. These latter, called "satellite" receivers, are quite simple in construction but incapable of operation in the absence of the main receiving unit.

## 2. Pulse Modulator

The pulse modulator consists of the following four main sections: audio-frequency amplifier-limiter, pulse generator and delay line, pulse-time-modulation units, and finally a section for mixing the eight channels and marker to form a complete train of time-division time-modulated pulses.

Programs from the eight different sources are supplied to the audio-frequency amplifier-limiters for modulating purposes. These amplifiers, which are gain controlled, have a response within 1 decibel from 30 to 10,000 cycles. For full modulation ( $\pm 1$  microsecond), an input level of 0 decibels is required (1 milliwatt in 600 ohms). The modulation excursions must be limited,

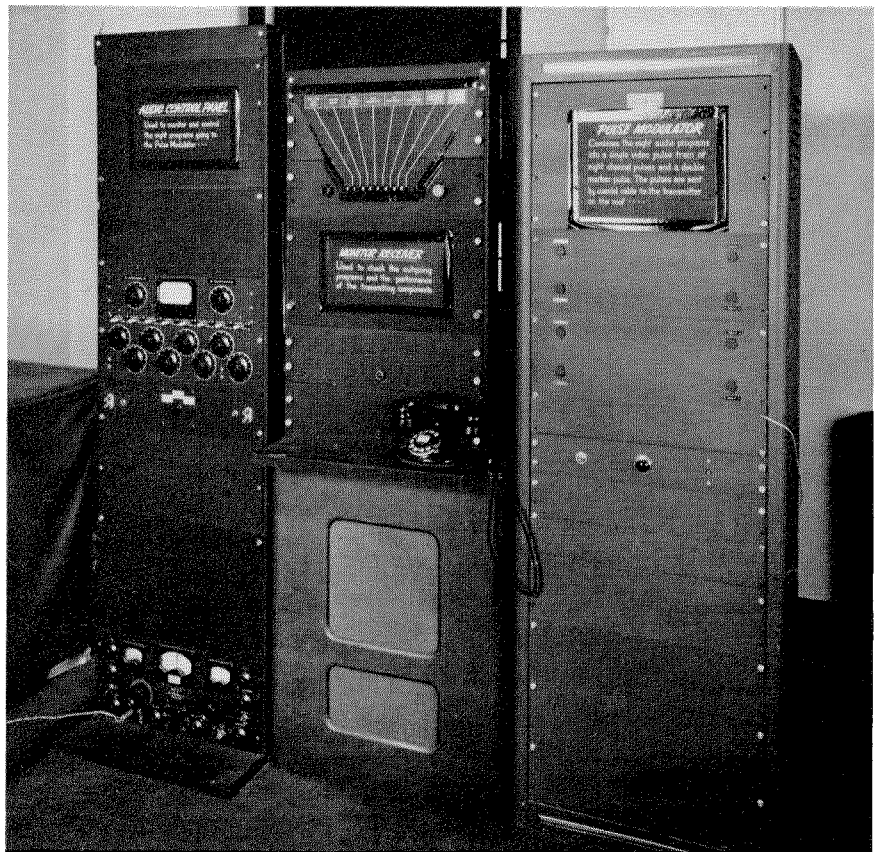

Figure 2—Experimental multiplex broadcasting system, showing the audio-frequency control panel, pulse modulator, and monitor receiver.



Figure 3—Omnidirectional eight-loop transmitting antenna for the experimental multiplex broadcasting system, located at 67 Broad Street in New York City.

however, so that any channel does not overmodulate and cause cross talk on any other channel by moving so far in timing that it appears in a position that might be held by an adjacent-channel pulse. To prevent this overmodulation,

limiters are placed across the audio-frequency input-transformer secondary. These consist of germanium crystals with a fixed bias voltage. The audio-frequency output is then used to modulate a sawtooth wave obtained in proper sequence and delay from the pulse generator.

The pulse generator and delay line make up a single compact unit. The electron-coupled oscillator in this unit determines the base repetition rate of the pulse frequency per channel and is, therefore, designed for very stable operation. In this particular system, that rate is 24 kilocycles. The sine-wave output is then shaped into a sawtooth having a 6-microsecond rise time, and this travels along the delay line from a cathode-follower. This delay line is so designed that it will pass the sawtooth without deteriorating the slope and with minimum attenuation. Taps at every 4.63 microseconds are connected to cathode-followers. Each cathode-follower is connected by a short piece of coaxial cable to the modulator input. This now supplies each channel modulator with a waveform having proper delay, a linear rise time, and the required



Figure 4—Master receiving console.

amplitude so that it may be operated on to obtain time modulation.

This is done by a circuit called the channel modulator.<sup>2</sup> As shown in Figure 5, this unit takes a slice of the incoming sawtooth wave and converts it to a square pulse. By changing the bias on this double clipper at an audio-frequency rate, a width-modulated pulse is obtained. Differentiating and using the leading edge pro-

pulses in the entire train, at even the remotest positions of modulation, ever come this close together. This then gives an identifying factor to the pulse train so that a selector device is able to distinguish the program channels. To produce such a double pulse, a single pulse is generated in an identical manner to the channel pulses and passed down an open-circuited delay line. This line has a delay of 0.65 microsecond, thus re-

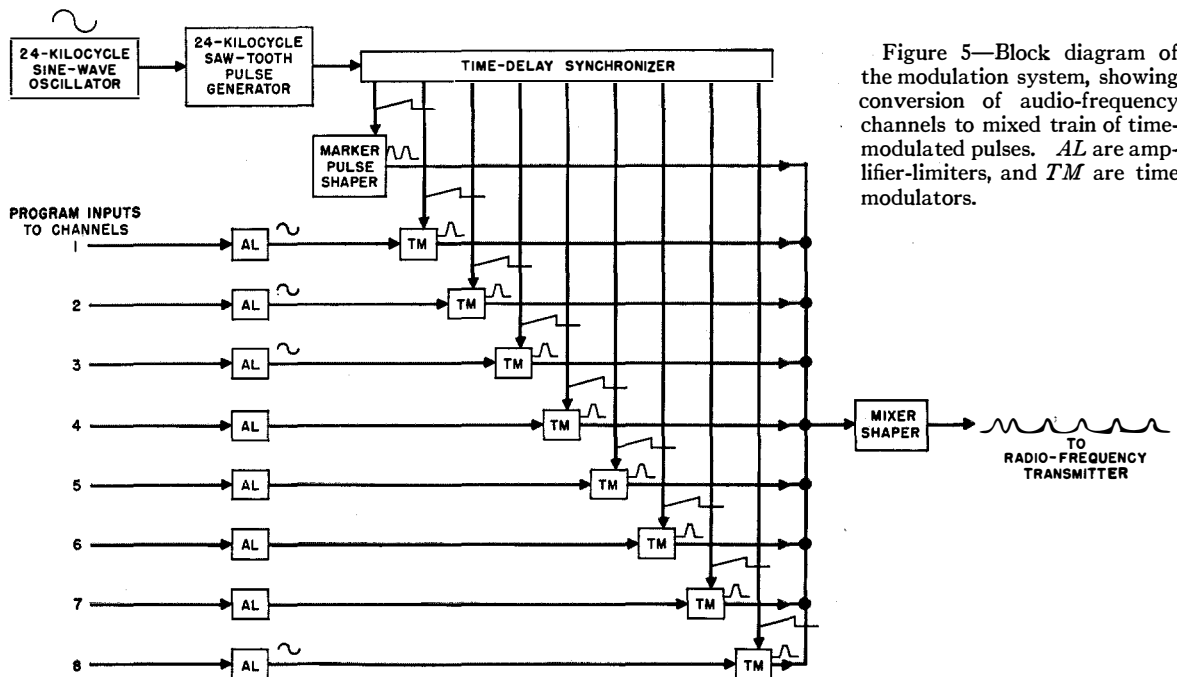

Figure 5—Block diagram of the modulation system, showing conversion of audio-frequency channels to mixed train of time-modulated pulses. *AL* are amplifier-limiters, and *TM* are time modulators.

duces a time-modulated pulse to be further shaped and processed. The channel pulses are 0.5 microsecond wide at an amplitude 10 percent above the base, and require 0.15 microsecond to build up to 0.9 or decay to 0.1 of maximum amplitude.

These channel pulses are clipped so that any amplitude modulation is removed, and they are then electronically mixed in such a manner that the pulse train is delivered from a cathode-follower to a 70-ohm coaxial cable. Besides the channel pulses, a marker pulse is supplied to the mixer. This marker consists of two pulses, identical in shape to the channel pulses, but spaced only 1.3 microseconds apart. No other two

quiring 1.3 microseconds for the pulse to travel along the line, reflect at the open-circuited end, and return to the starting point. The resulting double pulse is mixed with the eight channel pulses, and the full train then goes to the transmitter modulator.

### 3. Transmitter Equipment

The transmitter proper, shown in Figure 6, consists essentially of two parts: the transmitter modulator and the radio-frequency oscillator, both mounted on a single 72-inch relay rack.

The transmitter modulator must amplify the low-amplitude pulse train coming from the pulse modulator and deliver signals at approximately 300 volts over a 50-ohm circuit to the grid of the oscillator. The output stage of the transmitter modulator employs two 807 tubes in parallel as

<sup>2</sup> D. D. Grieg and A. M. Levine, "Pulse-Modulated Multiplex Radio Relay System—Terminal Equipment," *Electrical Communication*, v. 23, pp. 159-178; June, 1946.



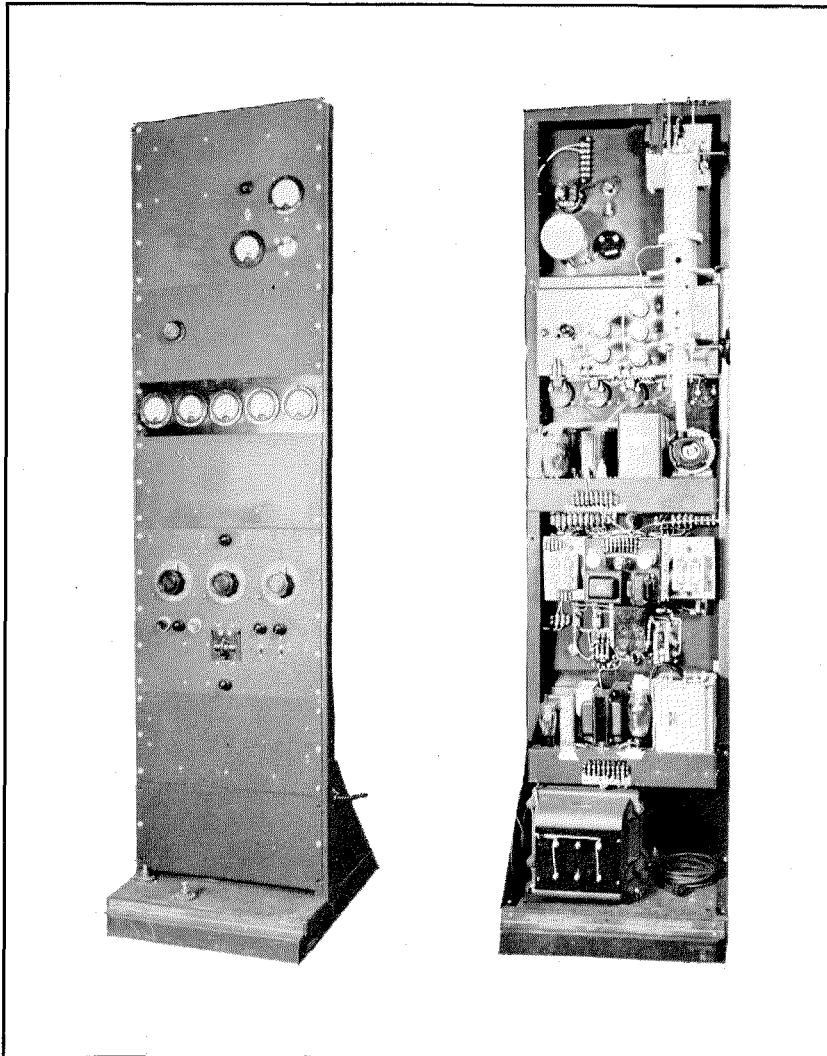

Figure 6—Front and back views of the transmitter unit.

decibels. Because of the type of modulation, linearity of amplification is unimportant and the tubes may be operated for maximum efficiency.

In the experimental installation, it was convenient to locate the pulse-modulator unit (Figure 2) several floors below the roof on which the transmitter and antenna were located. This necessitated a good resistive termination (accurate matching) of the cable carrying the pulse signals between the two units; any mismatch at this point would produce reflections that would travel back down the cable and cause objectionable cross talk.

For the radio-frequency generator, both triodes and magnetrons were considered. More power was possible with available magnetrons and, had the operating frequency been higher in the ultra-high-frequency range, a magnetron would have been chosen. However in the

cathode-followers. The design follows that of a conventional video-frequency amplifier with the same precautions for linear phase shift and flat frequency response of both the low and high end of the video-frequency spectrum. In this particular case, 3 megacycles was chosen as the highest frequency and 400 cycles as the point where the low-frequency response was down 3 decibels. Both of these points were chosen for reasons of cross talk and maintenance of pulse characteristics for a signal-to-noise improvement<sup>3</sup> over amplitude modulation of about 20

1000-megacycle region, triode circuitry is simpler and more flexible for an initial experimental unit. A triode oscillator of the tuned-plate tuned-cathode variety using a type 2214B tube was, therefore, used. The circuit is shown schematically in Figure 7. An adjustable grid "bell," fitting coaxially over the cathode line, provides the necessary feedback. Both plate and grid modulation are feasible, though the latter is somewhat simpler. The experimental unit produced a peak output of 500 watts or more, with an average power output not exceeding 50 watts.

An important consideration of transmitter design for this type of application is the question of frequency stability. An automatic-frequency-

<sup>3</sup>E. M. Deloraine and E. Labin, "Pulse Time Modulation," *Electrical Communication*, v. 22, n. 2, pp. 91-98; 1944.

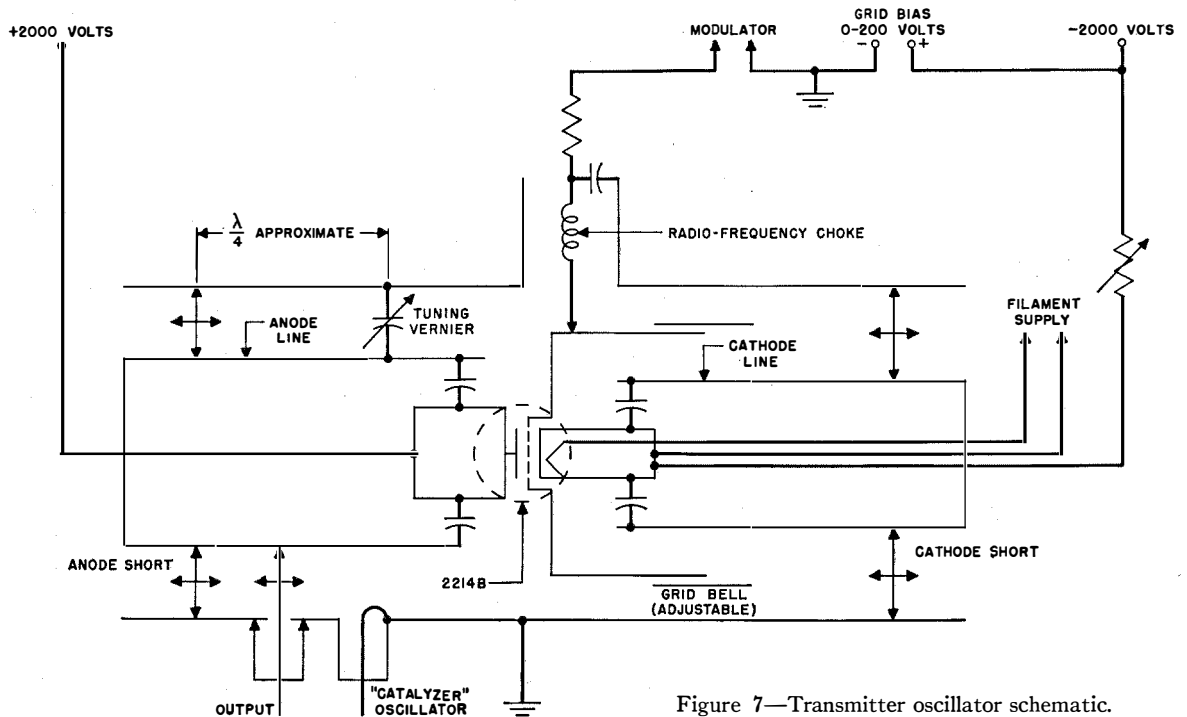

Figure 7—Transmitter oscillator schematic.

control system, to hold the center frequency stable with high precision, is feasible for both magnetron or triode oscillators. A crystal frequency-control system with a series of multipliers to the final operating frequency, or more simply a master-oscillator power-amplifier combination, are also feasible through the 1000-megacycle region. In the present case, however, a frequency-stabilizing system did not appear to contribute sufficiently to the initial experimental tests to justify the additional equipment and complication.

Tests indicated that the inherent frequency instability, drift, etc., of the radio-frequency oscillator, described above, under all the various operating conditions did not exceed  $\pm 0.4$  megacycle; this is quite tolerable since the total radio-frequency bandwidth is nearly 6 megacycles. For any final equipment design of a multiplex broadcasting system, a frequency-stabilizing circuit could be readily incorporated.

In a pulse-time system of modulation, a very important consideration is the uniformity of the starting time of the individual oscillations each time the oscillator is pulsed. Experiments show that, even when the pulses are very accurately timed, there is likely to be a considerable random

variation of this factor. The reason for this is, apparently, the fact that a random noise signal of a certain minimum amplitude is necessary to initiate the radio-frequency oscillations when the direct-current pulse is applied to the tube. This random variation in timing of the pulses is only a small portion of 1 microsecond (which represents full modulation), but produces a noise signal that may be only 30 decibels below the full-modulation signal. By optimum adjustment of the oscillator feedback circuit, it is possible to minimize this source of noise. A more practical solution is to couple to the transmitter oscillator cavity the output of a small continuous-wave radio-frequency oscillator of a type normally used for receiver local oscillators. This auxiliary oscillator—called the catalyzer oscillator—provides sufficient signal level to insure a starting time of oscillations substantially independent of any random-noise variation. Experimentally, it was determined that the catalyzer oscillator frequency could deviate considerably from the pulsed-oscillator frequency without appreciable change in performance.

In addition to the above, the transmitter has the usual monitoring equipment, including an echo-box-type cavity for checking frequency and

a reflectometer-detector to monitor output radio-frequency power as well as the standing-wave ratio on the output transmission line to the antenna. A radio-frequency detector coupled to this transmission line plus a pulse-time-modulation demodulator allows complete over-all monitoring of the programs on the eight separate channels.

#### 4. Transmitting Antenna

As in the majority of broadcast applications, the radiated transmitter power must be omnidirectional in the horizontal plane to give uniform coverage within the broadcast service area. Also, in line with conventional practice, horizontal polarization was chosen. The basic radiator that provides omnidirectional horizontally polarized radiation is the horizontal loop antenna, used in a large number of applications in the very-high-frequency range, including aerial navigation and frequency-modulation broadcasting.

To reinforce the radiation in the horizontal plane and reduce wasteful high- and low-angle radiation, a vertical stack of eight square loops (shown in Figure 3) is used. This compresses the vertical radiation pattern to approximately 9 degrees between the half-power points, and thus provides a power gain of approximately 8 compared to a half-wave dipole. Larger gain than this is feasible, and for a final design, a stack of 16 or more loops may be used.

The transmission-line problem is quite important in the 1000-megacycle region. Most reliable are standardized solid-dielectric cables. However their power-handling capacity is limited, and the amount of attenuation, if long lengths are to be used, is quite substantial. Available air-dielectric lines do not have these limitations, but have disadvantages of their own, namely: discontinuities due to beads and connectors. Furthermore, gas-

ing or air-drying equipment is necessary to keep moisture out for operation over any period of time. Waveguides would perhaps be practical for a final installation, but were considered to be too bulky for an initial experimental setup. In the present case, only 30 feet of line was necessary and *RG-17/U* solid-dielectric cable was used. The attenuation is less than 1.5 decibels, which is quite tolerable. Solid-dielectric cable is also used for the feeders within the antenna array. The antenna and transmission-line system has given satisfactory operation under all weather conditions encountered during summer and winter.

#### 5. Receiving Equipment

The receiving equipment installation at Nutley consisted of antenna, cable, one master receiver, and several satellite receivers to reproduce simultaneously at least four of the eight broadcast channels.

Since in a multiplex broadcasting system all programs originate from the same transmitting site, it is evident that a highly directive receiving antenna oriented along the direction of propagation may be used. This means not only a great increase in the signal strength received, but also a substantial decrease in interfering signals. In the ultra-high-frequency range, a great deal of directivity may be obtained quite economically. In the present case, a 4-foot dish with a simple dipole giving an antenna power gain of approximately 50 was used. A more compact, though less directive, horn antenna was used for portable reception in field tests with a station wagon. Solid-dielectric *RG-8/U* cable connects the antenna to the master receiver.

An over-all block diagram of the complete receiver is shown in Figure 8. The superheterodyne circuit uses a *2C40* local oscillator and a *1N28*

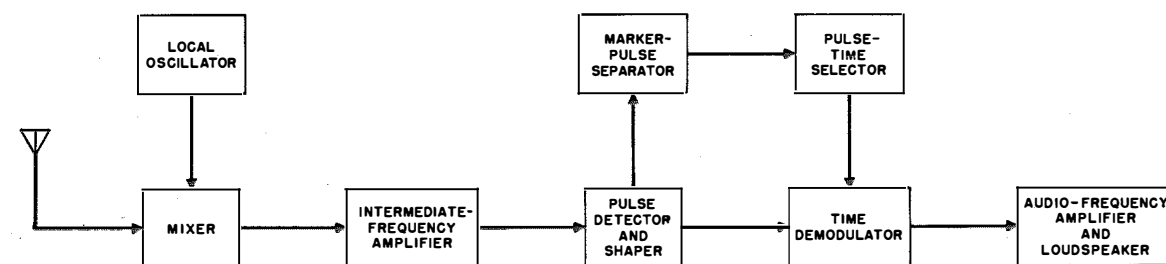

Figure 8—Block diagram of the pulse-time-modulation receiver.

crystal mixer with intermediate-frequency output at 30 megacycles. No tuning of any radio-frequency circuit is necessary for channel selection, because this is done entirely at video frequencies. A schematic of the local oscillator and mixer circuit is shown in Figure 9. No radio-frequency amplification is used since, at these frequencies, the crystal-mixer input circuit provides a somewhat better over-all receiver noise-figure performance than would a tube-amplifier input circuit. However, this is only true if the intermediate-frequency input circuit is properly designed. Figure 10 shows a schematic of the intermediate-frequency preamplifier, which follows the mixer.

The preamplifier circuit has a noise figure of 2.5 decibels—that is, the actual circuit noise is only 2.5 decibels greater than the ideal limit. This is achieved by the use of triode tubes and unusual design of the input network, as well as the assembly and adjustment of the mixer and preamplifier in a single unit.

Referring to Figure 10, the output from a high-

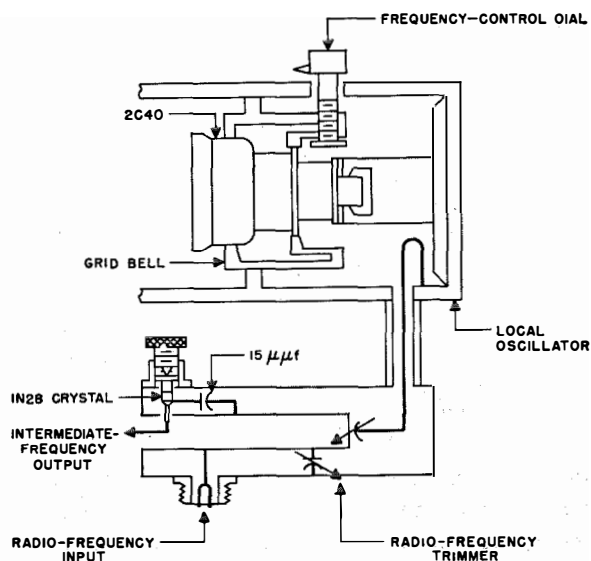

Figure 9—Schematic diagram of the local oscillator and mixer unit for receiver.

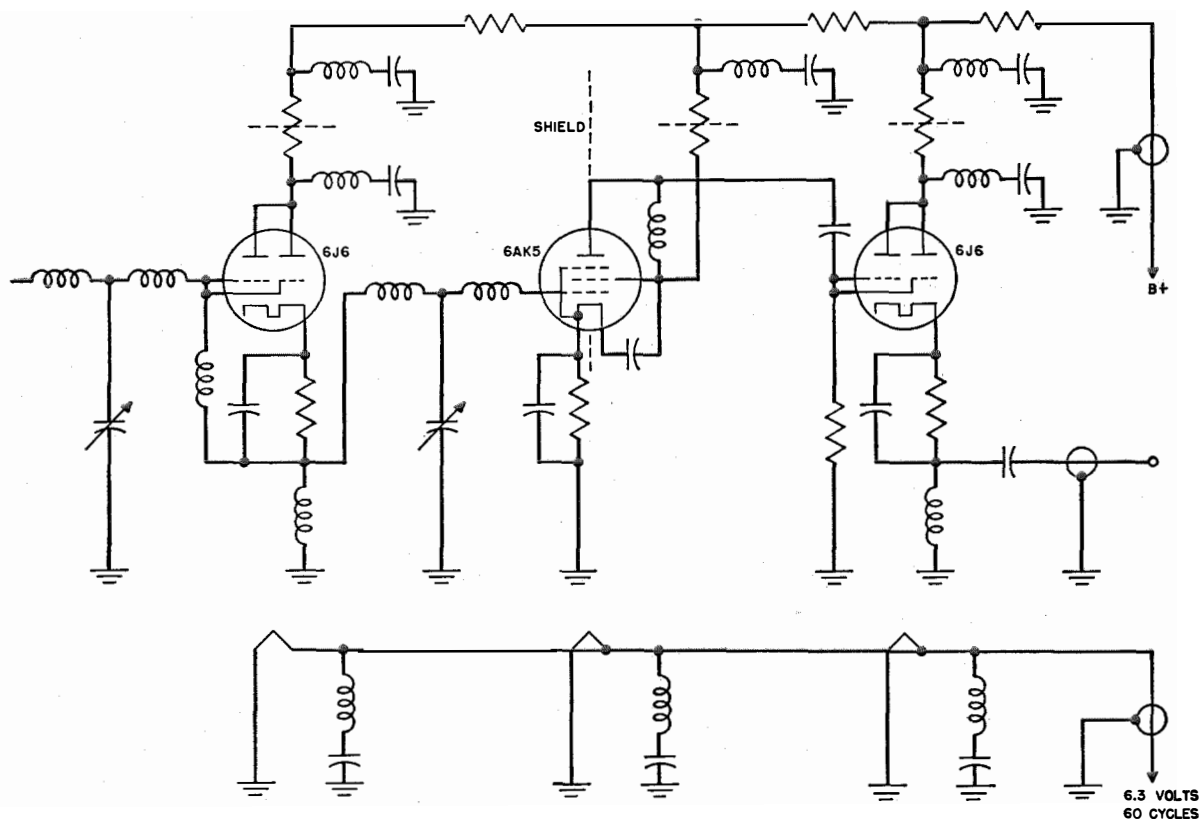

Figure 10—Schematic circuit of the low-noise intermediate-frequency preamplifier unit.

mutual-conductance triode  $6J6$  used as a cathode-follower, passes to the grid of a  $6AK5$  through a matching network that is equivalent to a step-up transformer. The degeneration of the cathode-follower allows increased input impedance, and permits the use of a triode while still providing power gain. A conventional pentode stage follows, amplifying the signal sufficiently to override the noise of following stages, and a cathode-follower provides a low-impedance output circuit.

Since the total noise contributed by the tubes is considerably less than the input thermal noise, the design of the input circuit becomes a major factor. If the input impedance is adjusted to match the source, the resistance noise of the input circuit is added to the equal resistance noise of the source, doubling the noise and limiting the noise factor to not less than 3 decibels. For the cathode-follower circuit used, optimum noise condition occurs with a mismatch of about 2:1 between mixer and preamplifier.

Due to the wide bandwidth, unequal primary and secondary  $Q$ 's, and large coefficient of coupling required, it was found convenient to replace the conventional input transformer by a two-section tapered filter, analogous to a tapered transmission line. This permitted the use of simple elements of inductance and capacitance, eliminating mutual inductance. Assembly of the mixer and preamplifier as a single unit eliminated the usual connecting cable; this was found highly desirable in view of the mismatch required at this point. Loading resistors are, of course, undesirable because of their thermal noise, and the loading in this case is provided almost entirely by the mixer, the amplifier input having an unloaded  $Q$  of nearly 50.

Since a cathode-follower may oscillate where the sign of the cathode load (reactance) is similar to that of the grid-cathode reactance and opposite to that of the grid-ground reactance, it was necessary to select configurations for the input and output networks satisfying certain added requirements of reactance versus frequency. It was also found that an inductance approximately resonating the grid-cathode capacitance of the  $6J6$  above the center of the frequency band (32 megacycles), improved performance by its effect on the loading reflected from the cathode circuit.

Figure 11 shows the experimental local oscillator, mixer, and intermediate-frequency pre-amplifier unit.

The main intermediate-frequency unit is stagger-tuned, having a gain of about 75 decibels. Each stage is fixed-tuned, the coil being wound on the basis of an average tube capacitance. No trouble was found in alignment, and change in tubes had negligible effect on band-pass characteristics. The intermediate-frequency pre-amplifier operates directly into a 50-ohm resistor so that there is no mistuning of any input circuit.

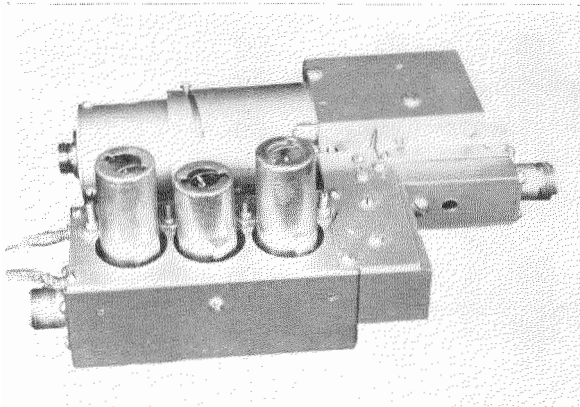

Figure 11—Experimental local-oscillator, mixer, and intermediate-frequency preamplifier unit.

There is a manual gain control in the first stage but this, once adjusted, is left untouched. The output of the last stage operates into a plate detector for added gain and one stage of video-frequency limiting follows this. A dual cathode-follower then supplies a train of pulses to the video-frequency demodulator, which has 70 ohms impedance.

Although most of the main intermediate-frequency unit is conventional, a great deal of care must be exercised in the design and operation of the limiters for best signal-to-noise ratio. Some form of automatic volume control must be used to insure that the intermediate-frequency stages themselves do not limit improperly. Unlike frequency modulation (Figure 12(A)), pulse-time-modulation requires "one-sided" limiting as shown in Figure 12(B). Therefore, good automatic-volume-control action must take place. If this were not true and an intermediate-frequency stage began limiting, the output signal-

to-noise might become worse than the incoming signal-to-noise. This is shown in Figure 12(C) and 12(D).

Figure 12(C) shows what the signal may look like when applied to an amplifier that limits, and

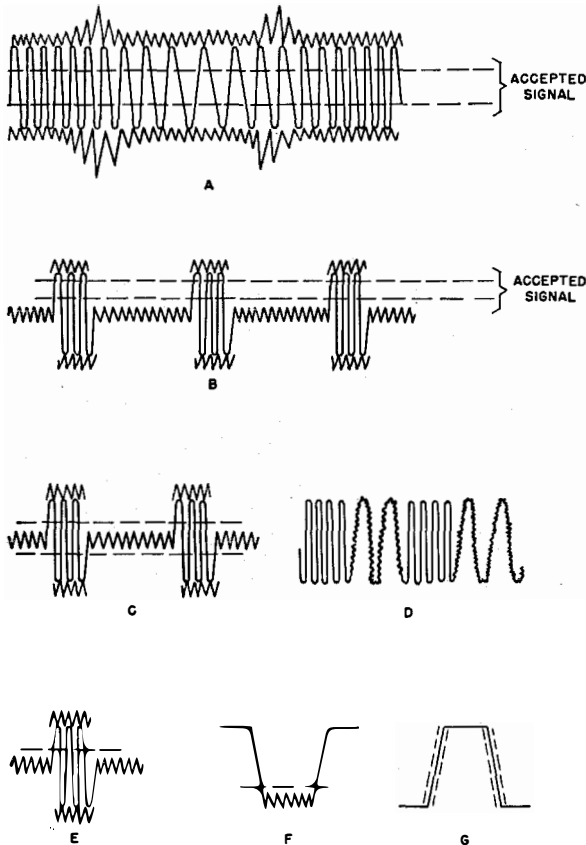

Figure 12—Schematic of proper intermediate-frequency limiting in the pulse-time-modulation system.

in Figure 12(D) can be seen what appears at the output. Proper pulse-time-modulation limiting can no longer take place, as the amplitude-modulated signal-to-noise ratio has been degraded. In this particular intermediate-frequency design, the type of automatic volume control was simple but effective. The last 3 stages of the strip preceding the detector contain "peak-riding" circuits in the grid with sufficiently long time constants so that no demodulation takes place. The plate detector is so biased as to remove noise on the base line. The negative output pulse is coupled to a video-frequency clipper, with direct-current restoring of the base line, so that top

clipping of the pulse results (Figures 12(E), 12(F), and 12(G)). Now the signal-to-noise improvement ratio of  $K(\Delta T_s/t\gamma)$  can properly take place.<sup>4</sup>  $\Delta T_s$  is the pulse deviation from midposition in microseconds,  $t\gamma$  is the time of pulse rise in microseconds, and  $K$  is a constant that includes the noise crest factor and ratio of pulse repetition rate to audio-frequency band used. The only noise remaining is that which has been translated into time modulation. These limited time-modulated pulses are then passed to the video-frequency demodulator or to the satellite receivers.

Two types of pulse demodulators are employed, one using conventional components and another type using a special single-channel Cyclophon.<sup>5</sup> Both sets use the double marker for obtaining a synchronizing pulse to identify the desired channel. The marker is separated by the same process as that used in the modulator, namely, by applying the train of pulses to an open-circuited delay line. Because only the marker pulses are 1.3 microseconds apart, the first pulse after traversing the delay line is superimposed on the second pulse, producing a combined pulse larger than all others.<sup>1</sup> This marker pulse is selected by amplitude from the train of channel pulses and performs two functions, channel separation and channel demodulation.

In the first type of receiver, a delay line with taps in the same time relation as that used at the transmitter, is employed to isolate each desired channel. The separated marker pulse, as shown in Figure 13, is widened, shaped, and transmitted along the delay line. This marker pulse is then applied to the control grid of a pentode biased to cutoff, while at the same time the entire series of pulses is applied to a second control grid. The  $6AS6$  is ideal for this purpose. The tube is keyed on at the appropriate time by the deblocking marker pulse, and the channel pulse is converted to amplitude modulation by "riding" the sloped top of the shaped marker pulse. Following this tube, a filter removes the pulse-frequency components and only audio-frequency currents pass

<sup>4</sup> B. Trevor, D. E. Dow and W. D. Houghton, "Pulse Time Division Radio Relay," *RCA Review*, v. 7, pp. 561-575; December, 1946.

<sup>5</sup> D. D. Grieg, J. J. Glauber, and S. Moskowitz, "The Cyclophon: A Multipurpose Commutator Tube," *Proceedings of the I.R.E.*, v. 35, pp. 1251-1257; November, 1947.

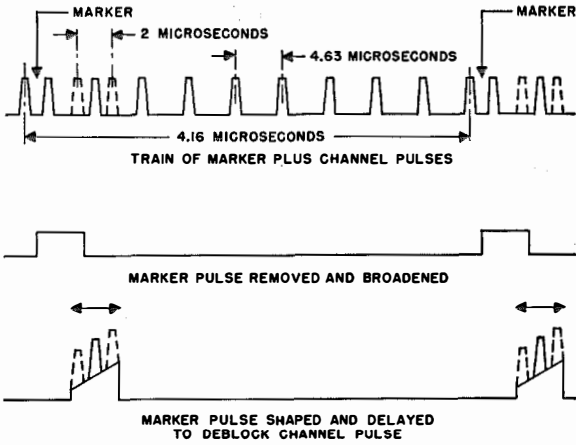

Figure 13—Operation of marker as channel separator and demodulator.

experienced. The method of operation is straightforward. A sawtooth wave, generated by the marker pulse in a single triode, is applied to the two deflecting plates of this cathode-ray-type tube and sweeps the beam across a plate at the end of the tube. At the same time, all the channel pulses are applied to the control grid of the Cyclophon, and the beam is on only while a pulse is present. The beam is so focused and positioned for the selected channel that the spot striking the end plate is half on and half off for zero modulation position. For all other channels, the beam is entirely away from the plate and produces no output. The plate current, flowing through the output load resistance, is proportional to the position of the beam as determined

on to the speech amplifier. This method of demodulation proved simple and reliable, requiring no adjustments after the receiver was aligned with the transmitter. The harmonic distortion at 400 cycles for the over-all system using this receiver was 2.5 percent. The signal-to-noise ratio at 100-percent modulation was 55 decibels.

A second method of channel separation and demodulation is unique in that it employs a single-channel Cyclophon. This tube, shown in Figure 14, is comparable in size to the metal 6L6. Use of this tube eliminates a great many circuit components, including the delay line, and saves much time in receiver alignment. Although the effectiveness of the tube depends largely on stable operating voltages, little trouble has been

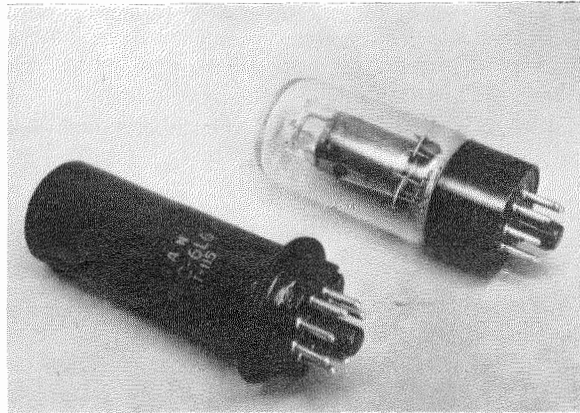

Figure 14—Single-channel Cyclophon compared with a 6L6 metal receiving tube.

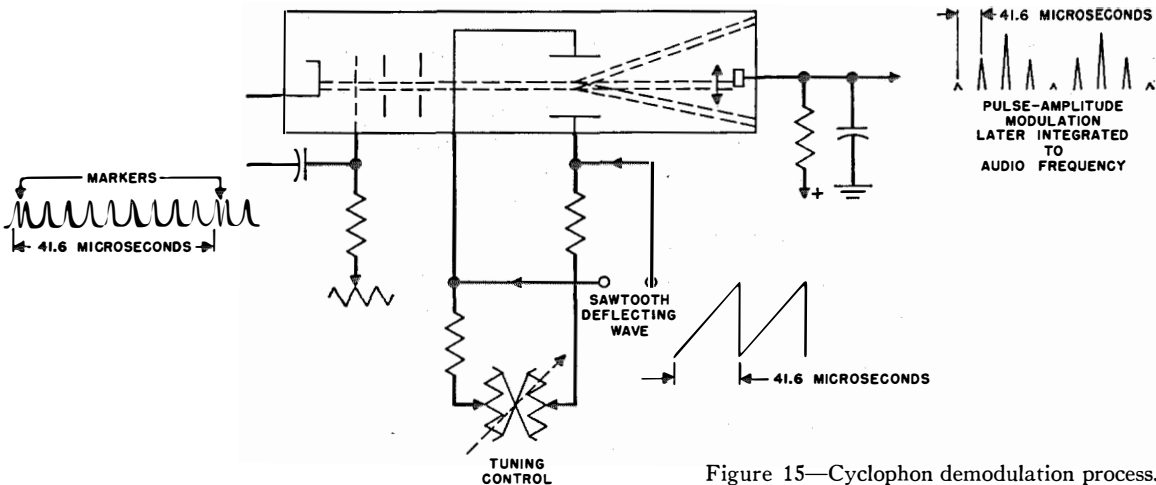

Figure 15—Cyclophon demodulation process.

by the timing of the pulse.<sup>5</sup> Hence, the output amplitude is proportional to the time modulation of the keying pulse. Channel selection takes place by merely shifting the centering voltage on the deflecting plates of this tube. Figure 15 illustrates this process.

### 6. Conclusions

The equipment described above was developed and operated for over a year, during which frequent tests and demonstrations were made to show its performance and versatility. From this experience the following conclusions are possible:

- A. Multiplex broadcasting appears feasible anywhere within the ultra-high-frequency spectrum.
- B. Over-all performance equivalent to or better than that required in standard broadcasting can be obtained at many locations. More comparative propagation data at ultra-high-frequencies are necessary before more precise conclusions can be drawn.
- C. The inherent advantages of high-efficiency and high-

gain antenna systems at ultra-high frequencies can be easily and economically realized in this system.

D. Because of the antenna gain, the transmitter size and power may be considerably reduced in comparison with equipment for lower frequencies.

E. Multiplex broadcasting receivers are little, if any, more complicated than standard amplitude- or frequency-modulation receivers of comparable quality. However, for any widespread use of multiplex broadcasting, the economics of the receiver is the major problem to be faced. The possible use of an inexpensive multiplexing attachment for a standard amplitude- or frequency-modulation receiver should be considered carefully.

### 7. Acknowledgment

As is true of most projects of this type and magnitude, many more people presented useful ideas and comments than can be listed here. Among those who contributed most substantially to the development of the various components that made up the complete system were R. T. Adams, D. D. Grieg, A. Horvath, A. Lesti, S. Moskowitz, and B. Parzen, all of Federal Telecommunication Laboratories.

---

### Recent Telecommunication Development

#### Kelvin Premium to Earp and Godfrey

THE KELVIN PREMIUM of the Institution of Electrical Engineers has been awarded to C. W. Earp and R. M. Godfrey of Standard Telephones and Cables, Limited, for their paper on "Radio Direction-Finding by the Cyclical Differential Measurement of Phase," which was published in the *Journal of the Institution of Elec-*

*trical Engineers*, volume 94, Part IIIA, pages 705-721, and reprinted in *Electrical Communication* for March, 1949.

This award is issued annually by the Institution of Electrical Engineers for the most meritorious paper on scientific research published by that society during the preceding year.



# Calculation of Band-Pass Filters Using Piezoelectric Crystals in Lattice Structures

By A. FROMAGEOT and M. A. LALANDE

*Laboratoire Central de Télécommunications, Paris, France*

THERE IS PRESENTED, a method of calculating the components of lattice filters in which the opposite arms consist of identical dipoles. This method is based on the fact that the critical frequencies of the dipoles (series and parallel resonances) included in the transmitted and in the attenuated ranges are computed independently. The first are related to the image attenuation constant and the second to the image impedance. The image attenuation constant is determined by the lowest required values in the attenuated range, i.e., the attenuation required from the filter. The image impedance is fixed by the average value and the deviation allowed around this value in the transmitted range.

Examples include the calculation of elements for three types of filters, and curves are provided to show the attenuation characteristics of filters constructed in accordance with these designs.

• • •

## 1. General

The components of an electric band-pass filter must often be calculated on the basis of the impedance-matching conditions within the transmitted band and the attenuation requirements outside this band. This is commonly the case in the design of multichannel telephone systems based on frequency division, particularly with regard to filters for selecting pilot and carrier frequencies, telephone channels, and groups of channels. These filters must provide a high attenuation outside and maintain a fairly uniform response within the transmitted band.

The attenuation requirements, it should be remembered, are not uniform over all the attenuated frequency range. Attenuation must be high at frequencies where existing currents are translated to the transmitted range by the action of the various carriers. As a convenient basis for our calculations, the frequency spectrum of these

unwanted currents can be drawn on a diagram to indicate the lower limits of attenuation that must be provided by the filter.

Concerning uniformity of response within the transmitted band, any difference between the image impedance of the filter and the terminal resistances, which establishes the impedance-matching conditions, can be expressed in a diagram similar to that for the attenuation requirements.

The design procedure to be described is based on conventional filter theory making use of image parameters, emphasizing particularly two theorems by H. W. Bode,<sup>1</sup> and the attenuation-gage method by E. Rumpelt.<sup>2</sup>

### 1.1 BODE'S TWO THEOREMS

A. Cut-off frequencies and infinite-attenuation frequencies (or poles of attenuation) determine the image attenuation of a filter.

B. A filter consisting of  $n$  sections in tandem, all with the same cut-off frequencies and image impedances, is equivalent to a single lattice section, the cut-off frequencies and image impedance of which are the same as those of the  $n$  sections.

According to these theorems, one can replace  $n$  sections in tandem, each section having a single pole of attenuation, by a single lattice section with  $n$  poles of attenuation, and reciprocally.

In accordance with theorem *B* and for particular cases met in practice, expressions will be given relating the parameters of a single section with  $n$  poles of attenuation to the parameters of  $n$  sections each with a single pole of attenuation. The usefulness of these relations resides in the facility with which the parameters of a single-pole section may be calculated.

<sup>1</sup>H. W. Bode, "A General Theory of Electric Wave Filters," *Journal of Mathematics and Physics*, v. 13, pp. 275-362; November, 1934. Also, Bell Laboratories Reprint 843.

<sup>2</sup>E. Rumpelt, "Schablonenverfahren für den Entwurf elektrischer Wellenfilter auf der Grundlage der Wellenparameter," *Telegraphen-Fernsprech-Funk-und Fernsichttechnik*, v. 31, pp. 203-210; August, 1942.

1.2 ATTENUATION-GAGE METHOD OF RUMPELT

In the attenuation-gage method of Rumpelt, the image attenuation of any filter section with a single pole of attenuation can be written as the following function of frequency  $f$ .

$$F[\lambda + \varphi(f)],$$

$\varphi$  and  $F$  being the same functions regardless of the type of filter section, and the value of  $\lambda$  being related to the frequency of infinite attenuation of the considered section.

According to this, if  $\varphi(f)$  is taken as the variable instead of  $f$ , the attenuation curve of any single-pole section can be deduced from the general function

$$P_0 = F[\varphi(f)]$$

by a translation of the coordinates parallel to the horizontal axis. The attenuation curve of an  $n$ -pole section can be obtained in the following way.

From Bode's theorems, the section under consideration can be replaced by  $n$  sections in tandem provided each has a single pole of attenuation; the attenuation  $P$  of the given section is equal to the sum of the attenuations  $P_i$  of the  $n$  single-pole sections, i.e.,

$$\begin{aligned} P &= P_1 + P_2 + \dots + P_n \\ &= F[\lambda_1 + \varphi(f)] + F[\lambda_2 + \varphi(f)] \\ &\quad + \dots + F[\lambda_n + \varphi(f)]. \end{aligned}$$

The curve  $P$  is therefore obtained by adding the ordinates of  $n$  functions  $P_0$ , which are shifted along the horizontal axis by values equal to  $\lambda_1, \lambda_2, \dots, \lambda_n$ .

Actually, the most frequent problem is the reverse of this; to find the filter that provides the required attenuation curve. To solve this, the curve of the required attenuation and the curve of the function  $P_0 = F[\varphi(f)]$  are drawn in terms of  $\varphi$  as the variable (the required attenuation curve provides a sort of gage, hence the name given to this method of calculation). Attenuation values at least equal to the required values are then found by adding the ordinates of several curves  $F[\varphi(f)]$  shifted along the horizontal axis to give best results. The values of  $\lambda_i$  are then deduced from the positions of the various  $F[\varphi(f)]$  curves, these values being the frequencies of

infinite attenuation. The attenuation poles being thus found, Bode's theorems state that the filter parameters are entirely determined if the cut-off frequencies and the image-impedance function are known. The filter can then consist either of single-pole sections in tandem, the number of sections being equal to the number of poles, or of more complex sections in tandem, each section having more than one pole and the number of these sections being such as to provide the required total number of poles.

1.3 LATTICE STRUCTURE

Consideration will be limited to lattice structures because they are actually utilized for crystal filters and they represent the most general case to be dealt with, since any type of section can be calculated as a lattice section.

1.3.1 Notations

A dipole  $Z$  consisting of inductances and capacitances is entirely defined by the frequencies at which its reactance is zero and infinite, and by its limiting value for either zero or infinite fre-

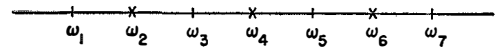

Figure 1—Dipole showing zero-reactance points by short vertical lines and infinite-reactance points by crosses.

quency. For instance, the impedance of a dipole having the zero and infinite frequencies shown in Figure 1 is

$$Z = \frac{L}{j\omega} \cdot \frac{(\omega_1^2 - \omega^2)(\omega_3^2 - \omega^2)(\omega_5^2 - \omega^2)(\omega_7^2 - \omega^2)}{(\omega_2^2 - \omega^2)(\omega_4^2 - \omega^2)(\omega_6^2 - \omega^2)}$$

and corresponds to the circuits of Figure 2.

By writing  $(j\omega)^2 = -u$ ,

$$Z = \frac{L}{j\omega} \cdot \frac{(u_1 - u)(u_3 - u)(u_5 - u)(u_7 - u)}{(u_2 - u)(u_4 - u)(u_6 - u)}$$

In the transmitted band of a lattice filter, the reactances of the series dipoles  $Z_A$  are of opposite signs to those of the diagonal dipoles  $Z_B$ ; these reactances have the same signs outside the transmitted band. A diagram of reactances  $Z_A$  and  $Z_B$  of a filter with a single pass band is shown in Figure 3.

The values of  $u$  corresponding to the cut-off frequencies will be noted as  $K_1$  and  $K_2$ , which as  $\alpha, \beta, \dots$ , also correspond to the zero-impedance and infinite-impedance critical frequencies of  $Z_A$  and  $Z_B$ .

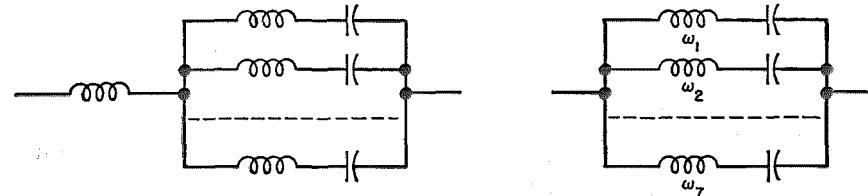

Figure 2—Circuits corresponding to dipole of Figure 1.

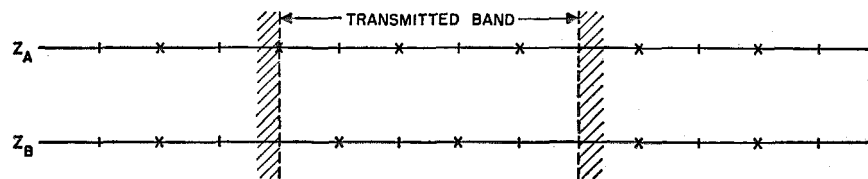

Figure 3—Reactances of series  $Z_A$  and diagonal  $Z_B$  dipoles of a lattice filter.

The two equations expressing the image parameters being:

$$\text{image impedance } Z = (Z_A Z_B)^{\frac{1}{2}}$$

and

$$\text{image transfer constant } P = th \frac{P}{2} = \left( \frac{Z_A}{Z_B} \right)^{\frac{1}{2}}$$

show that

A. The critical frequencies belonging to the transmitted band determine the image transfer constant  $P$  or, more precisely, the attenuation poles and the frequencies for which the image phase constant is  $k$ .

B. The critical frequencies belonging to the attenuated band determine the image impedance and, accordingly, the impedance matching in the transmitted band.

The method of choosing the attenuation poles for obtaining a required attenuation characteristic has been traced in Section 1.2; a method of choosing perfectly matching frequencies, so that the response of the filter is kept within required limits, is given in Section 3, these last frequencies determine the critical frequencies of  $Z_A$  and  $Z_B$  for the attenuated range.

Two problems have been considered separately. The first concerns band-pass filters, the bandwidth of which is small enough not to require any critical frequency of  $Z_A$  and  $Z_B$  within the attenuated band. In that case, the relation between the filter components and the infinite-

attenuation frequencies will be indicated. It is also possible to calculate the filter components, being given the frequencies at which the image phase constant is  $k\pi$ . This problem will not be considered here as it does not appear to have any practical utility due to the large difference between the image phase constant and the effective phase constant measured when the filter is terminated by resistances. This problem of narrow-band-pass filters is dealt with in Section 2.

The second problem concerns band-pass, high-pass, and low-pass filters having large bandwidths. Then, it may be necessary to choose for  $Z_A$  and  $Z_B$

dipoles presenting critical frequencies outside the transmitted range and such that the image impedance matches properly the terminal resistances within all the transmitted range. It will be shown that in this problem the frequencies for which the image impedance is equal to the terminal resistance may be found in a similar manner as were the frequencies of infinite attenuation in the first problem. This second problem is dealt with in Section 3.

### 2. Narrow-Band-Pass Filters

As previously stated, a narrow-band-pass filter is defined by its image impedance, cut-off frequencies, and its  $n$  poles of attenuation. To calculate its components, we shall consider an  $n$ -section filter having the same image impedance as the filter to be designed but having only a single attenuation pole.

At this point, it is useful to review all the possible lattice sections having a single attenuation pole, and for which the dipoles  $Z_A$  and  $Z_B$  have no critical frequencies in the attenuation band. There are four such sections, which differ from one another by their image-impedance functions; this function depends on whether the cut-off frequencies are zero- or infinite-reactance frequencies of  $Z_A$  or  $Z_B$ . The main features of

these fundamental sections are indicated in Table 1, which shows also those sections having the same image impedance as one of the four fundamental sections and several poles of attenuation.

The following of these sections are often met in practical designs.

*Type I.3* is used for selecting telephone channels in single-sideband equipment; dipoles  $Z_A$  and  $Z_B$  are made of a piezoelectric crystal in series with an inductance.

*Type III.2* is used for selecting a pilot or carrier frequency; dipoles  $Z_A$  and  $Z_B$  are made of piezoelectric crystal. This lattice section is often transformed to the equivalent Jaumann section.

*Type I.5* is used for selecting telephone channels in single-sideband equipments; dipoles  $Z_A$  and  $Z_B$  are made of two piezoelectric crystals in parallel, in series with an inductance.

Equations for filter sections type I.3 and III.2 have been published.<sup>3</sup> Equations for type I.5 have not been completely developed in technical papers<sup>4</sup> and these will be given in detail as an example of the method described in Section 1.

2.1 CALCULATION OF FILTER SECTION TYPE I.5

In calculating the components of a filter section of type I.5, the impedance of dipoles  $Z_A$  and  $Z_B$

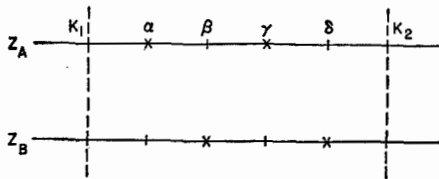

Figure 4—Impedances of dipoles  $Z_A$  and  $Z_B$  for filter section of type I.5.

are considered to be as indicated in Figure 4, using the notations of Section 1.3.1

$$Z_A = \frac{L_A (K_1 - u)(\beta - u)(\delta - u)}{j\omega (\alpha - u)(\gamma - u)}, \tag{1}$$

$$Z_B = \frac{L_B (\alpha - u)(\gamma - u)(K_2 - u)}{j\omega (\beta - u)(\delta - u)}. \tag{2}$$

<sup>3</sup> W. P. Mason, "Resistance-Compensated Band-Pass Crystal Filters for Use in Unbalanced Circuits," *Bell System Technical Journal*, v. 16, pp. 423-436; October, 1937.

<sup>4</sup> W. P. Mason and R. A. Sykes, "Electrical Wave Filters Employing Crystals with Normal and Divided Electrodes," *Bell System Technical Journal*, v. 19, pp. 221-248; April, 1940.

The image parameters are

$$Z = (L_A L_B)^{\frac{1}{2}} \left[ \frac{(u - K_1)(K_2 - u)}{u} \right]^{\frac{1}{2}}, \tag{3}$$

$$th \frac{P}{2} \left( \frac{L_A}{L_B} \right)^{\frac{1}{2}} \cdot \left( \frac{K_1 - u}{K_2 - u} \right)^{\frac{1}{2}} \times \frac{(\beta - u)(\delta - u)}{(\alpha - u)(\gamma - u)} = m \left( \frac{K_1 - u}{K_2 - u} \right)^{\frac{1}{2}} \times \frac{(\beta - u)(\delta - u)}{(\alpha - u)(\gamma - u)}. \tag{4}$$

The equation  $th(P/2) = \pm 1$ , the roots of which correspond to the frequencies of infinite attenuation, is of the 5th degree; this section provides, therefore, 5 poles of attenuation, corresponding to  $n$  values designed by  $a_1, a_2, a_3, a_4, a_5$ .

2.1.1 Calculation of Critical Frequencies of Dipoles and of  $m$  in Terms of  $a_i$ 's

The  $a_i$ 's are the basic data of the filter. They are determined by the method of Rumpelt and are chosen in such a way that the image attenuation obtained with five attenuation poles has values greater than those indicated by the required attenuation diagram. For calculating the values of  $\alpha, \beta, \gamma,$  and  $\delta$  in terms of the  $a_i$ 's,  $K_1, K_2,$  and the maximum value  $R_0$  of the image impedance, the expression of the image attenuation of the wanted section is identified with the image attenuation given by five sections, each section having only one pole of attenuation corresponding, respectively, to one of the values  $a_1, a_2, \dots, a_5,$  and to the same cut-off frequencies and image impedance as the desired section.

$$t = th \frac{P}{2} = th \left( \frac{P_1 + P_2 + \dots + P_5}{2} \right) = \frac{\sum t_i + \sum t_i t_j t_k + t_1 t_2 t_3 t_4 t_5}{1 + \sum t_i t_j + \sum t_i t_j t_k t_l},$$

where

$$t_i = th \frac{P_i}{2} m_i \left( \frac{K_1 - u}{K_2 - u} \right)^{\frac{1}{2}} = m_i R, \tag{5}$$

$$m_i = \left( \frac{K_2 - a_i}{K_1 - a_i} \right)^{\frac{1}{2}}. \tag{6}$$

Let us write

$$\left. \begin{aligned} A &= \sum m_i, \\ B &= \sum m_i m_j, \\ C &= \sum m_i m_j m_k, \\ D &= \sum m_i m_j m_k m_l, \\ E &= \sum m_1 m_2 m_3 m_4 m_5. \end{aligned} \right\} \tag{7}$$

TABLE 1

LATTICE SECTIONS WITH ONE ATTENUATION POLE, THE ARMS OF WHICH HAVE NO CRITICAL FREQUENCIES IN THE ATTENUATED RANGE

NATURE OF CUT-OFF FREQUENCIES		ZERO-REACTANCE FREQUENCIES	INFINITE-REACTANCE FREQUENCIES	ONE ZERO- AND ONE INFINITE-REACTANCE FREQUENCY	ONE INFINITE- AND ONE ZERO-REACTANCE FREQUENCY
IMPEDANCE OF THE ARMS	Z <sub>A</sub>	$\frac{K_1 K_2 L_A}{j\omega (K_1 - u)} \text{---} \frac{L_A C_A}{L_A C_A}$	$\frac{K_1 K_2}{C_A K_1 - u} \text{---} \frac{j\omega L_A C_A}{L_A C_A}$	$\frac{K_1 K_2}{j\omega C_A K_2 - u} \text{---} \frac{L_1 C_1}{L_1 C_1}$	$\frac{K_1 K_2}{j\omega L_A K_2 K_1 - u} \text{---} \frac{L_1 C_1}{L_A C_A}$
	Z <sub>B</sub>	$\frac{L_B}{j\omega (K_2 - u)} \text{---} \frac{L_B C_B}{L_B C_B}$	$\frac{j\omega L_B}{C_B K_2 - u} \text{---} \frac{L_B C_B}{L_B C_B}$	$\frac{1}{j\omega C_B} \text{---} \frac{C_B}{C_B}$	$j\omega L_B \text{---} \frac{L_B C_B}{L_B C_B}$
IMAGE IMPEDANCE Z	$Z = (L_A L_B)^{\frac{1}{2}} \left[ \frac{(u - K_1)(K_2 - u)}{u} \right]^{\frac{1}{2}} \frac{1}{K_1 K_2}$	$Z = \frac{1}{(C_A C_B)^{\frac{1}{2}}} \left[ \frac{u}{(u - K_1)(K_2 - u)} \right]^{\frac{1}{2}} \frac{1}{K_1 K_2}$	$Z = \frac{1}{(C_A C_B)^{\frac{1}{2}}} \left[ \frac{u}{(u - K_1)(K_2 - u)} \right]^{\frac{1}{2}} \frac{1}{K_1 K_2}$	$Z = \frac{1}{(C_A C_B)^{\frac{1}{2}}} \left[ \frac{(u - K_1)}{u(K_2 - u)} \right]^{\frac{1}{2}} \frac{1}{K_1 K_2}$	$Z = (L_A L_B)^{\frac{1}{2}} \left[ \frac{K_1 u(K_2 - u)}{K_2 (u - K_1)} \right]^{\frac{1}{2}} \frac{1}{K_1 K_2}$
VALUE OF Z FOR $u = (K_1 K_2)^{\frac{1}{2}}$	$(L_A L_B)^{\frac{1}{2}} \times 2\pi(f_2 - f_1) = R_0$	$\frac{1}{(C_A C_B)^{\frac{1}{2}}} \frac{1}{2\pi(f_2 - f_1)} = R_0$	$\frac{1}{(C_A C_B)^{\frac{1}{2}}} \frac{1}{(K_2)^2} = R_0$	$(L_A L_B)^{\frac{1}{2}} (K_1)^{\frac{1}{2}} = R_0$	
IMAGE TRANSFER CONSTANT VALUE OF $t_h (P/2)$	$\left(\frac{L_A}{L_B}\right)^{\frac{1}{2}} \left(\frac{K_1 - u}{K_2 - u}\right)^{\frac{1}{2}} m = \left(\frac{L_A}{L_B}\right)^{\frac{1}{2}}$	$\left(\frac{C_B}{C_A}\right)^{\frac{1}{2}} \left(\frac{K_2 - u}{K_1 - u}\right)^{\frac{1}{2}} m = \left(\frac{C_B}{C_A}\right)^{\frac{1}{2}}$	$\left(\frac{C_B}{C_A}\right)^{\frac{1}{2}} \left(\frac{K_1 - u}{K_2 - u}\right)^{\frac{1}{2}} m = \left(\frac{C_B}{C_A}\right)^{\frac{1}{2}}$	$\left(\frac{L_A K_1}{L_A K_2}\right)^{\frac{1}{2}} \left(\frac{K_2 - u}{K_1 - u}\right)^{\frac{1}{2}} m = \left(\frac{L_A}{L_B}\right)^{\frac{1}{2}}$	
VALUE OF u FOR INFINITE ATTENUATION (ATTENUATION POLE) $u=0$	$m = \left(\frac{K_2 - a}{K_1 - a}\right)^{\frac{1}{2}} \quad a = \frac{K_2 - m^2 K_1}{1 - m^2}$	$m = \left(\frac{K_1 - a}{K_2 - a}\right)^{\frac{1}{2}} \quad a = \frac{K_1 - m^2 K_2}{1 - m^2}$	$m = \left(\frac{K_2 - a}{K_1 - a}\right)^{\frac{1}{2}} \quad a = \frac{K_2 - m^2 K_1}{1 - m^2}$	$m = \left(\frac{K_1 - a}{K_2 - a}\right)^{\frac{1}{2}} \quad a = \frac{K_1 - m^2 K_2}{1 - m^2}$	
VALUES OF COMPONENTS IN TERMS OF $a, R_0, K_1,$ AND $K_2$	$L_p = \frac{R_0}{2\pi(f_2 - f_1)} \quad m = \left(\frac{K_2 - a}{K_1 - a}\right)^{\frac{1}{2}}$	$C_0 = \frac{1}{R_0 2\pi(f_2 - f_1)} \quad m = \left(\frac{K_1 - a}{K_2 - a}\right)^{\frac{1}{2}}$	$C_0 = \frac{1}{R_0 2\pi f_2} \quad m = \left(\frac{K_2 - a}{K_1 - a}\right)^{\frac{1}{2}}$	$L_p = \frac{R_0}{2\pi f_1} \quad m = \left(\frac{K_1 - a}{K_2 - a}\right)^{\frac{1}{2}}$	
	$L_A = mL_p \quad L_B = \frac{L_p}{m}$ $C_A = \frac{1}{K_1 L_A} \quad C_B = \frac{1}{K_2 L_B}$	$C_A = \frac{1}{m} C_0 \quad C_B = m C_0$ $L_A = \frac{1}{K_1 C_A} \quad L_B = \frac{1}{K_2 C_B}$	$C_A = \frac{1}{m} C_0 \quad C_B = m C_0$ $L_1 = \frac{1}{(K_2 - K_1) C_A} \quad C_1 = \frac{1}{K_1 L_1}$	$L_A = mL_p \quad L_B = \frac{L_p}{m}$ $L_1 = L_A \frac{K_1}{K_2 - K_1} \quad C_1 = \frac{K_2 - K_1}{L_A K_1 K_2}$	
SECTIONS WITH SAME IMAGE IMPEDANCE					
ATTENUATION POLES	EQUIVALENT SECTIONS	$K_1 \quad a \quad K_2$	$\times \quad \times \quad \times$	$\times \quad \times \quad \times$	$\times \quad \times \quad \times$
2	2	$K_1 \quad a \quad \beta \quad K_2$	$\times \quad \times \quad \times \quad \times$	$\times \quad \times \quad \times \quad \times$	$\times \quad \times \quad \times \quad \times$
3	3	$K_1 \quad a \quad \beta \quad \gamma \quad K_2$	$\times \quad \times \quad \times \quad \times \quad \times$	$\times \quad \times \quad \times \quad \times \quad \times$	$\times \quad \times \quad \times \quad \times \quad \times$
4	4	$K_1 \quad a \quad \beta \quad \gamma \quad \delta \quad K_2$	$\times \quad \times \quad \times \quad \times \quad \times \quad \times$	$\times \quad \times \quad \times \quad \times \quad \times \quad \times$	$\times \quad \times \quad \times \quad \times \quad \times \quad \times$
5	5		$\times \quad \times \quad \times \quad \times \quad \times \quad \times$	$\times \quad \times \quad \times \quad \times \quad \times \quad \times$	$\times \quad \times \quad \times \quad \times \quad \times \quad \times$

We then obtain for  $t$

$$t = R \cdot \frac{A + CR^2 + ER^4}{1 + BR^2 + DR^4},$$

i.e.,

$$t = \left( \frac{K_1 - u}{K_2 - u} \right)^3 \times \frac{A(K_2 - u)^2 + C(K_1 - u)(K_2 - u) + E(K_1 - u)^2}{(K_2 - u)^2 + B(K_1 - u)(K_2 - u) + D(K_1 - u)^2} \quad (8)$$

$\alpha, \beta, \gamma,$  and  $\delta$  are given by the following equations, expressing the sum and product of the roots of the numerator and denominator of  $t$ .

$$\left. \begin{aligned} S = \beta + \delta &= \frac{(2A + C)K_2 + (C + 2E)K_1}{A + C + E}, \\ P = \beta\delta &= \frac{AK_2^2 + CK_1K_2 + EK_1^2}{A + C + E}, \\ T = \alpha + \gamma &= \frac{(2 + B)K_2 + (B + 2D)K_1}{1 + B + D}, \\ S = \alpha\gamma &= \frac{K_2^2 + BK_1K_2 + DK_1^2}{1 + B + D}. \end{aligned} \right\} \quad (9)$$

Moreover,

$$m = \frac{A + C + E}{1 + B + D} \quad (10)$$

In case  $L_A = L_B$ , one of the  $m_i$ 's equals 1, and also  $m = 1$ . One can then replace the inductances  $L_A$  and  $L_B$  by inductances introduced in series outside the lattice and consider the loss resistance of these inductances as part of the terminal impedance.

In the following calculations, assume  $L_A = L_B$ , and write

$$\left. \begin{aligned} A &= 1 + A', & B &= A' + B', & C &= B' + C', \\ D &= C' + D', & E &= D', \\ A + C + E &= 1 + B + D \\ &= 1 + A' + B' + C' + D'. \end{aligned} \right\} \quad (11)$$

### 2.1.2 Calculation of Components of Dipole $Z_A$

The dipole  $Z_A$  is represented in Figure 5. From this is obtained

$$Z_A = \frac{L_A}{j\omega} \frac{(K_1 - u)(\beta - u)(\delta - u)}{(\alpha - u)(\gamma - u)} \quad (12)$$

$L_A$  is known when the value  $R_0$  of the image impedance for  $u = (K_1K_2)^{\frac{1}{2}}$  is known.

$$Z = R_0 = 2\pi(f_2 - f_1)L_A.$$

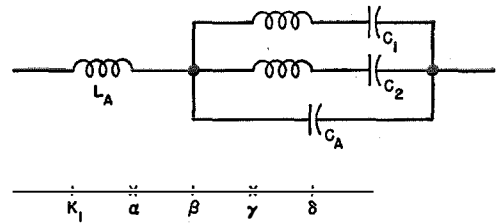

Figure 5—Representation of dipole  $Z_A$ .  
 $Q_1 = 1/(L_1C_1)$  and  $Q_2 = 1/(L_2C_2)$ .

The expressions for  $C_A, L_1, L_2, Q_1, Q_2$  (see Figure 5) are obtained in the following way. First,  $Z_A$  as given by (12) is reduced to

$$j\omega L_A + Z_A'$$

and  $1/Z_A'$  to

$$j\omega C_A + \frac{j\omega}{L_1(Q_1 - u)} + \frac{j\omega}{L_2(Q_2 - u)}$$

as indicated in Figure 6.

$$C_A = \frac{1}{L_A} \frac{1}{K_1 + S - T}, \quad (13)$$

$$\left. \begin{aligned} Q_1 + Q_2 &= \frac{K_1S + P - Q}{K_1 + S - T}, \\ Q_1Q_2 &= \frac{K_1P}{K_1 + S - T}. \end{aligned} \right\} \quad (14)$$

Finally  $L_1$  and  $L_2$  are given by

$$\left. \begin{aligned} \frac{1}{L_1} + \frac{1}{L_2} &= \frac{1}{L_A} \frac{(S - T)(T - K_1) - (P - Q)}{(K_1 + S - T)^2}, \\ \frac{1}{L_1Q_1} + \frac{1}{L_2Q_2} &= \frac{1}{L_A} \frac{Q(S - T) - K_1(P - Q)}{K_1P(K_1 + S - T)}. \end{aligned} \right\} \quad (15)$$

The calculation of the elements of dipole  $Z_B$  is exactly the same.

### 2.1.3 Facilities for Numerical Computation

The preceding equations are difficult to use in practice: the frequencies  $F = (1/2\pi)Q^{\frac{1}{2}}$  corresponding to  $Q_1$  and  $Q_2$  must be known within an accuracy of the order of  $10^{-5}$ . To obtain this accuracy for the two magnitudes  $F$  that are calculated in terms of  $Q_1 + Q_2$  and  $Q_1Q_2$ , it is necessary to calculate these last expressions with an accuracy of the order of

$$10^{-5} \cdot \Delta F / F$$

with

$$\Delta F = F_2 - F_1 \ll F_1 \cong F_2 \cong F.$$

For instance, for  $\Delta F = 2$  kilocycles and  $F = 140$  kilocycles, it is necessary to calculate  $Q_1 + Q_2$  and  $Q_1 Q_2$  within an accuracy of the order of  $10^{-7}$ , i.e., with seven figures.

Numerical computations are made easier if the factor  $(K_2 - K_1)$  is made to appear in the expression of the component values, this factor being known accurately. In that way, the equations become:

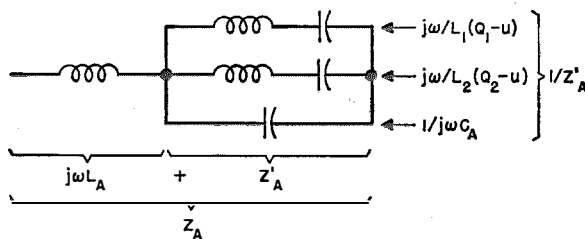

Figure 6—Derivation of  $Z_A$  and  $1/Z'_A$ .

$$\begin{aligned}
 Q_2 + Q_1 &= \frac{(2D' + B')K_1^2 + (2 + A' + B' + 2C')K_1K_2 + A'K_2^2}{K_1(1 + B' + D') + K_2(A' + C')}, \\
 Q_2 - Q_1 &= \frac{(K_2 - K_1)[(B'^2 - 4D')K_1^2 + A'^2K_2^2 + 2(A'B' - 2C')K_1K_2]^{\frac{1}{2}}}{K_1(1 + B' + D') + K_2(A' + C')}, \\
 \frac{L_A}{L_1} + \frac{L_A}{L_2} &= \frac{(K_2 - K_1)^2(A' + 2C' + B'C' - A'D')}{[K_1(1 + B' + D') + K_2(A' + C')]^2}, \\
 \frac{1}{Q_1} \frac{L_A}{L_1} + \frac{1}{Q_2} \frac{L_A}{L_2} &= \frac{(K_2 - K_1)^2[K_1(C' + B'C' - A'D') + K_2(A' + C')]}{K_1[K_1(1 + B' + D') + K_2(A' + C')][D'K_1^2 + (B' + C')K_1K_2 + (1 + A')K_2^2]}.
 \end{aligned} \tag{16}$$

In the same way,

$$\begin{aligned}
 Q_4 + Q_3 &= \frac{C'K_1^2 + (2A' + B' + C' + 2D')K_1K_2 + (2 + B')K_2^2}{K_1(A' + C') + K_2(1 + B' + D')}, \\
 Q_4 - Q_3 &= \frac{(K_2 - K_1)[C'^2K_1^2 + (B'C' - 2A'D')K_1K_2 + (B'^2 - 4D')K_2^2]^{\frac{1}{2}}}{K_1(A' + C') + K_2(1 + B' + D')}, \\
 \frac{L_A}{L_3} + \frac{L_A}{L_4} &= \frac{(K_2 - K_1)^2(A'B' + 2A'D' + C'D' - C')}{[K_1(A' + C') + K_2(1 + B' + D')]^2}, \\
 \frac{1}{Q_3} \frac{L_A}{L_3} + \frac{1}{Q_4} \frac{L_A}{L_4} &= \frac{(K_2 - K_1)^2[K_1D'(A' + C') + K_2(A'B' + A'D' - C')]}{K_2[K_1(A' + C') + K_2(1 + B' + D')][(C' + D')K_1^2 + (B' + C')K_1K_2 + K_2^2]}.
 \end{aligned} \tag{17}$$

The values of  $\alpha$ ,  $\beta$ ,  $\gamma$ , and  $\delta$  may be useful for adjusting the filter components; they are given by the following equations, where  $K_2 - K_1$  appears directly.

$$\begin{aligned}
 \beta + \delta &= \frac{(2A + C)K_2 + (C + 2E)K_1}{A + C + E} = \frac{(2 + 2A' + B' + C')K_2 + (B' + C' + 2D')K_1}{1 + A' + B' + C' + D'}, \\
 (\beta - \delta) &= \frac{(K_2 - K_1)(C^2 - 4AE)^{\frac{1}{2}}}{A + C + E} = \frac{(K_2 - K_1)[(B' + C')^2 - 4(1 + A')D']^{\frac{1}{2}}}{1 + A' + B' + C' + D'}, \\
 \alpha + \gamma &= \frac{(2 + B)K_2 + (B + 2D)K_1}{1 + B + D} = \frac{(2 + A' + B')K_2 + (A' + B' + 2C' + 2D')K_1}{1 + A' + B' + C' + D'}, \\
 (\alpha - \gamma) &= \frac{(K_2 - K_1)(B^2 - 4D)^{\frac{1}{2}}}{1 + B + D} = \frac{(K_2 - K_1)[(A' + B')^2 - 4(C' + D')]^{\frac{1}{2}}}{1 + A' + B' + C' + D'}.
 \end{aligned} \tag{18}$$

**3. Wide-Band Filter**

In the case of a wide-band filter, the uniformity of attenuation in the transmitted band, when measured between resistances, cannot be obtained at several frequencies without providing a perfect match between the image impedance of the filter and the terminating resistances. These frequencies are hereafter called perfectly matching frequencies.

**3.1 GENERAL METHOD OF CALCULATING WIDE-BAND FILTERS**

It is well known that the image transfer constant and the image impedance can be computed separately, because the first is controlled only by the critical frequencies of  $Z_A$  and  $Z_B$  within the transmitted range, whereas the second is controlled by the critical frequencies in the attenuated range. Reciprocally, one can determine the critical frequencies of  $Z_A$  and  $Z_B$  that are within the transmitted band independently of those in the attenuated range, the first being related to the image transfer constant, the second to the image impedance.

Accordingly, being given an attenuation gage in the attenuated range on the one hand and limits for image-impedance variations in the transmitted range on the other hand, the method described hereafter provides a means for obtain-

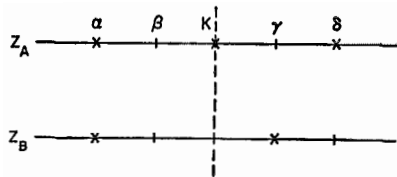

Figure 7—Arms of the proposed lattice filter.

$$Z_A = \frac{j\omega}{C_A} \frac{(\beta - u)(\gamma - u)}{(\alpha - u)(K - u)(\delta - u)}$$

$$Z_B = j\omega L_B \frac{(\beta - u)(\delta - u)}{(\alpha - u)(\gamma - u)}$$

ing from the first, the frequencies of infinite attenuation, then the critical frequencies of  $Z_A$  and  $Z_B$  in the transmitted range, and finally the image attenuation of the required filter; from the second, frequencies of perfect matching, then the critical frequencies of  $Z_A$  and  $Z_B$  in the attenuated range, and finally the image impedance of the required filter. Knowing all the critical

frequencies of  $Z_A$  and  $Z_B$ , the values of these components can be deduced.

To make this method more intelligible, we shall apply it to a specific example; the calculation of a high-pass filter having three poles of attenuation and three perfectly matching impedances, the cut-off frequency being an infinite-reactance frequency of one of the arms of the lattice.

Figure 7 shows the diagram of the arms of the proposed lattice filter. The image impedance  $Z$  and the image-transfer constant  $P$  are given by

$$Z = \left(\frac{L_B}{C_A}\right)^{\frac{1}{2}} \cdot \left(\frac{u}{u-K}\right)^{\frac{1}{2}} \cdot \frac{\beta-u}{\alpha-u}, \tag{20}$$

$$\left. \begin{aligned} th \frac{P}{2} = t &= \frac{1}{(C_A L_B)^{\frac{1}{2}}} \cdot \frac{1}{(K-u)^{\frac{1}{2}}} \cdot \frac{\gamma-u}{\delta-u} \\ &= m \frac{K^{\frac{1}{2}}}{(K-u)^{\frac{1}{2}}} \cdot \frac{\gamma-u}{\delta-u} \end{aligned} \right\} \tag{21}$$

Let us call  $R_T$  the value of the terminating resistances of the filter. Each of the equations  $Z = R_T th(P/2) = 1$  has three roots: therefore, a lattice filter having its arms  $Z_A$  and  $Z_B$  as shown in Figure 7 provides the required number of attenuation poles and perfectly matching frequencies.

**3.1.1 Calculation of Critical Frequencies Related to P**

The image transfer attenuation  $P_i$  of a section having the same image impedance as the considered lattice, but providing only one attenuation pole at a frequency  $f_i$ , where  $f_i^2 = a_i^2 / (4\pi^2)$ , is

$$th \frac{P_i}{2} = t_i = \frac{m_i (K)^{\frac{1}{2}}}{(K - a_i)^{\frac{1}{2}}}, \quad i = 1, 2, 3. \tag{22}$$

The  $m_i$  are related to the attenuation poles  $a_i$  by

$$m_i = \left(\frac{K - a_i}{K}\right)^{\frac{3}{2}}. \tag{23}$$

As previously written,

$$P = P_1 + P_2 + P_3 \tag{24}$$

and

$$\left. \begin{aligned} P_i &= F[\lambda_i + \varphi(f)], \\ F(z) &= \ln \left| \frac{1+e^z}{1-e^z} \right|, \\ \lambda_i &= -\ln m_i = -\ln \left(\frac{K - a_i}{K}\right)^{\frac{3}{2}}, \\ \varphi(f) &= \ln \left(\frac{K - u}{K}\right)^{\frac{1}{2}} = \ln \left(\frac{K - 4\pi^2 f^2}{K}\right)^{\frac{1}{2}} \end{aligned} \right\} \tag{25}$$



Exactly as explained before, the image-attenuation gage is drawn according to the required attenuation conditions, and attenuation values larger than the gage are obtained by adding the ordinates of three curves  $F[\varphi(f)]$  when they are arranged to give the best results. The positions of the three curves  $F[\varphi]$  give the values of  $\lambda_i$  and, consequently, of  $m_i$  and  $a_i$ . The values of  $\gamma$  and  $\delta$  are then calculated from (24), which can be written,

$$t = \frac{t_1 + t_2 + t_3 + t_1 t_2 t_3}{1 + t_1 + t_2 + t_1 t_3 + t_2 t_3}$$

Replacing  $t$  and  $t_i$  by the values given by (21) and (22), and writing

$$\left. \begin{aligned} A &= \sum_i m_i, \\ B &= \sum_{ij} m_i m_j, \\ C &= m_1 m_2 m_3, \end{aligned} \right\} \quad (26)$$

we finally obtain

$$\left. \begin{aligned} m &= A, \\ \gamma &= K + (C/A), \\ \delta &= K + B. \end{aligned} \right\} \quad (27)$$

### 3.1.2 Calculation of Critical Frequencies Related to Z

Again, two problems must be solved in calculating the critical frequencies related to Z.

A. Find the perfectly matching frequencies, so that  $Z/R$  remains as near unity as possible within the transmitted range.

B. Calculate the critical frequencies of  $Z_A$  and  $Z_B$  located in the attenuated range in terms of the perfectly matching frequencies.

To solve the first problem, use is made of a procedure similar to the attenuation-gage method of Rumpelt. We write:

$$\left. \begin{aligned} th Y = \frac{Z}{R} &= \frac{1}{R} \left( \frac{L_B}{C_A} \right)^{\frac{1}{2}} \left( \frac{u}{u-K} \right)^{\frac{1}{2}} \frac{\beta-u}{\alpha-u} \\ &= u \left( \frac{u}{u-K} \right)^{\frac{1}{2}} \cdot \frac{\beta-u}{\alpha-u}, \end{aligned} \right\} \quad (28)$$

the equation in  $u$ .

$$th Y = 1$$

has three roots  $b_1, b_2,$  and  $b_3$  corresponding to the perfectly matching frequencies. The quantities

$Z/R$  and  $th(P/2)$  having a similar form,  $Y$  can be replaced by the sum of three functions  $Y_1, Y_2, Y_3$ .

$$Y = Y_1 + Y_2 + Y_3 \quad (29)$$

with

$$Y_i = F[\lambda_i + \psi(f)] \quad (30)$$

such that

$$th Y_i = \mu_i \left( \frac{u}{u-K} \right)^{\frac{1}{2}} \quad (31)$$

The constants  $\mu_i$  and the functions  $\psi(f)$  and  $F(z)$  are given by

$$\left. \begin{aligned} \lambda_i &= \ln \mu_i = \ln \left( \frac{b_i - K}{b_i} \right)^{\frac{1}{2}}, \\ \psi(f) &= \ln \left( \frac{f^2 - K/4\pi^2}{f^2} \right)^{\frac{1}{2}}, \\ F(z) &= \ln \frac{1 + e^z}{1 - e^z}. \end{aligned} \right\} \quad (32)$$

The gage of the impedance-matching function  $Y$  is drawn in terms of  $\psi$  as the variable, and we try to locate three functions  $F(\psi)$ , shifted along the  $\psi$  axis for best results, so that their sum is everywhere larger than the required gage. The position of these three curves  $F(\psi)$  gives the values of  $\lambda_1, \lambda_2,$  and  $\lambda_3$  and, consequently, of  $b_1, b_2,$  and  $b_3$ .

For calculating the critical frequencies of  $Z_A$  and  $Z_B$  related to  $Z$  in the attenuated range, replace  $Y$  and  $Y_i$  in (29) by their values given by (28) and (31) and write, as previously,

$$\begin{aligned} A_1 &= \sum_i \mu_i, \\ B_1 &= \sum_{ij} \mu_i \mu_j, \\ C_1 &= \mu_1 \mu_2 \mu_3, \end{aligned}$$

and finally obtain

$$\begin{aligned} \mu &= \frac{A_1 + C_1}{1 + B_1}, \\ \alpha &= \frac{K}{1 + B_1}, \\ \beta &= \frac{A_1 K}{A_1 + C_1}. \end{aligned}$$

When a larger number of critical frequencies is involved, this method gives directly the sum, the sum of products by groups of two, three, etc., of the terms  $\alpha, \beta, \dots$ .

3.1.3 Calculation of Components of Dipoles  $Z_A$  and  $Z_B$

$Z_A$  and  $Z_B$  are entirely defined by the values of  $\alpha, \beta, \gamma, \delta, m,$  and  $\mu$ . The values of the inductances and capacitances of dipoles  $Z_A$  and  $Z_B$  are obtained by well-known methods making use of Foster's theorem.

3.1.4 Summary for Practical Use

Figure 8 represents the basic function

$$F(\varphi) = \frac{1+e^\varphi}{1-e^\varphi}, \quad (\varphi \text{ or } \psi).$$

For drawing the attenuation gages, it is necessary to transform the variable  $f$  to the variable  $\varphi$  or  $\psi$  as given in Table 2 ( $f_1$  and  $f_2$  are the cut-off frequencies).

TABLE 2  
TRANSFORMATION OF  $f$  TO  $\varphi$  OR  $\psi$

	High Pass	Low Pass	Band Pass
$\varphi$ Attenuation Gage	$\frac{1}{2} \ln \left( 1 - \frac{f^2}{f_1^2} \right)$	$-\frac{1}{2} \ln \left( 1 - \frac{f_1^2}{f^2} \right)$	$\frac{1}{2} \ln \frac{(f_2+f)(f_2-f)}{(f_1+f)(f_1-f)}$
$\psi$ Matching Gage	$\frac{1}{2} \ln \left( 1 - \frac{f_1^2}{f^2} \right)$	$\frac{1}{2} \ln \left( 1 - \frac{f^2}{f_1^2} \right)$	$\frac{1}{2} \ln \frac{f_2^2(f^2-f_1^2)}{f^2(f_2^2-f^2)}$

4. Practical Examples

4.1 CHANNEL-SEPARATING FILTERS FOR SINGLE-SIDEBAND RADIOTELEPHONY

Filters for separating channels in a single-sideband radiotelephone system are formed by assembling two or three lattice network sections of type I.3 of Table 1; each arm of the lattice is equivalent to the dipole of Figure 9.

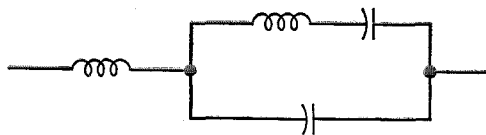

Figure 9—Equivalent dipoles for lattice arms for networks of type I.3.

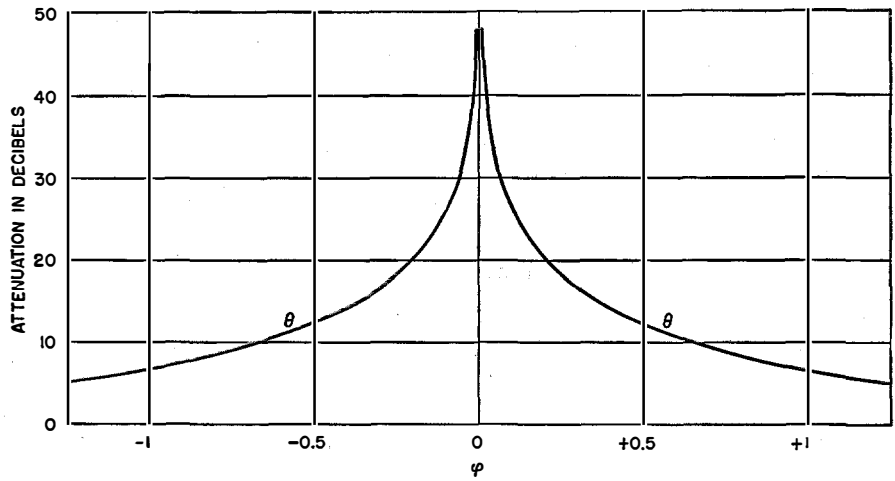

Figure 8—Basic function  $\frac{1+e^\varphi}{1-e^\varphi}$ .

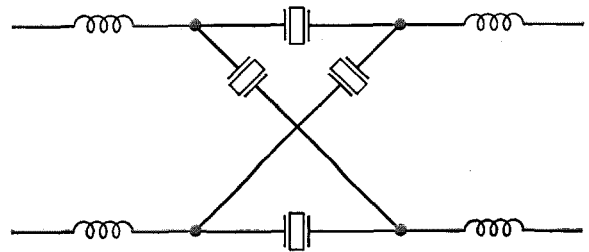

Figure 10—Equivalent circuit of I.3 network with series coils placed outside the lattice.

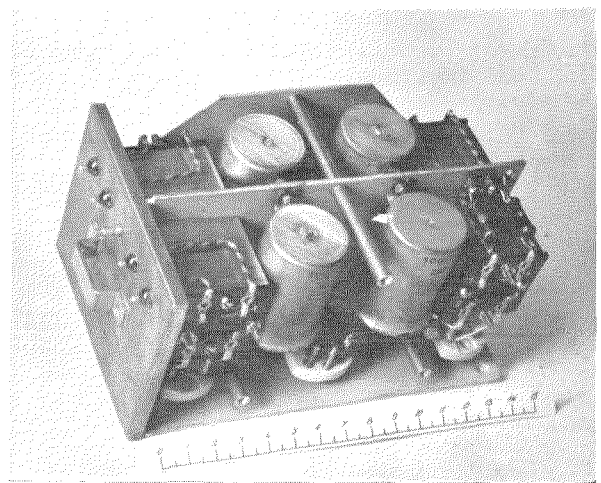

Figure 11—Construction of filter having characteristics shown in Figure 12. The scale is in centimeters.

Figure 12—Attenuation curve of filter used to reject the unwanted sideband in a single-sideband radiotelephone transmitter.

The series coil is the same for both series and shunt arms; the equivalent circuit of a section is shown in Figure 10, because it is possible to omit from the lattice the series coils, which are identical in all arms. These sections have two attenuation poles at finite frequencies and one at infinite frequency.

As a practical example, consider those filters at the sending end that are used for rejecting the unwanted sideband after the first modulation. They are made of two sections.

Figure 11 shows such a filter and Figure 12 is the attenuation curve of the filter.

A second practical example is the filter used before the last frequency changer in the receiver. These filters are provided with 12 attenuation poles at finite frequencies, six being located in the lower attenuated range and six in the upper attenuated range. There are also three attenuation poles at

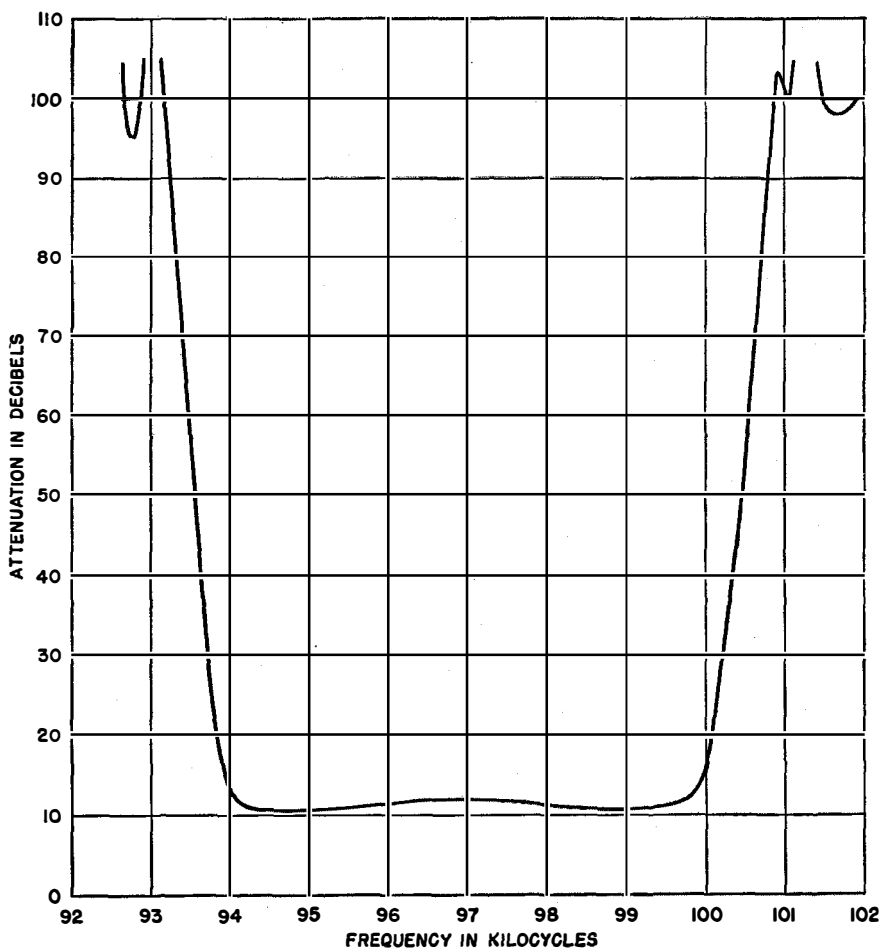
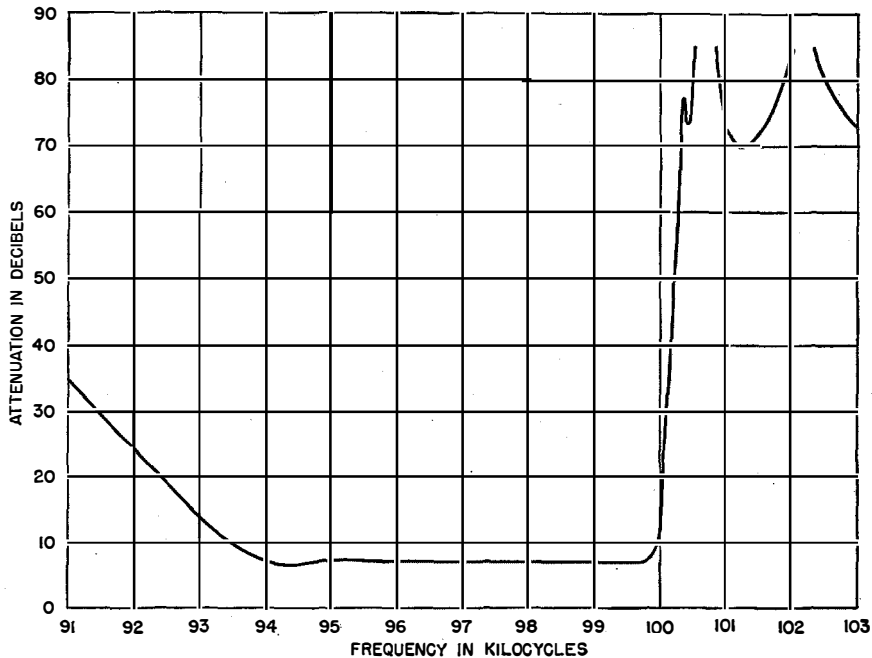

Figure 13—Attenuation curve of receiving filter for single-sideband system.

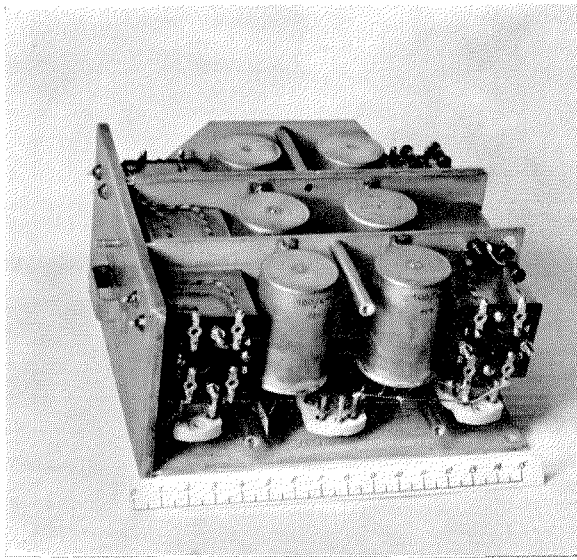

Figure 14—Filter having characteristics shown in Figure 13.

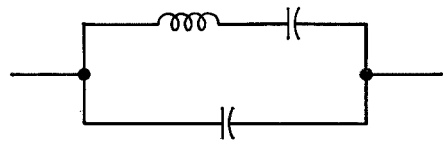

Figure 15—Type of dipole used in pilot-selecting filter for single-sideband radiotelephone receiver.

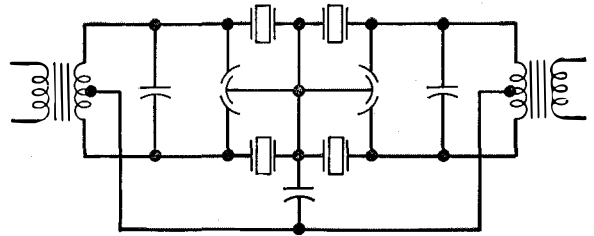

Figure 16—Electrical circuit of pilot-selecting filter.

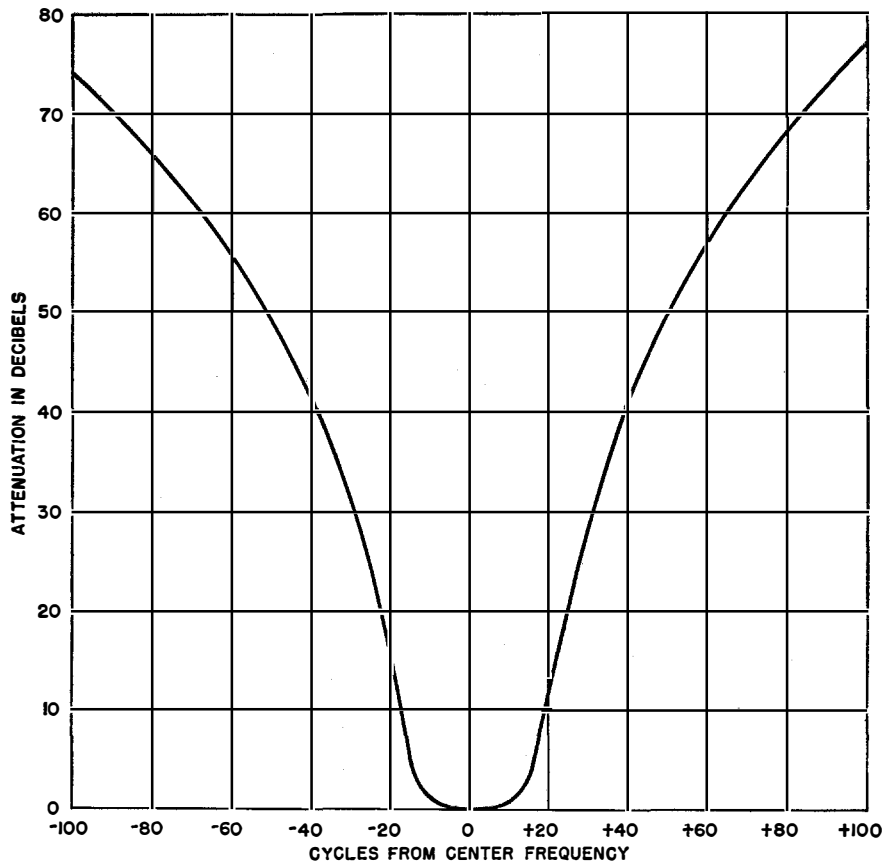

Figure 17—Attenuation characteristic of pilot filter plotted from a center frequency of 100 kilocycles. At 90 decibels, the band is 600 cycles wide.

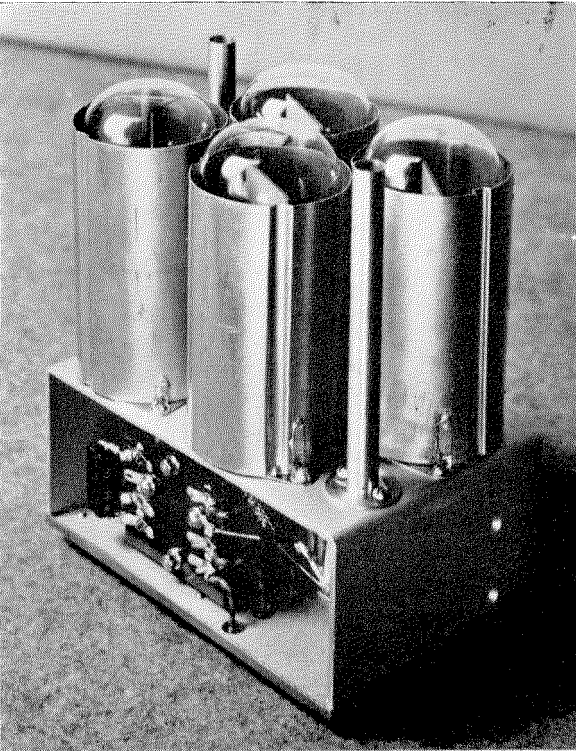

Figure 18—Pilot-selecting filter.

infinite frequency. These filters are made of three lattice network sections.

The required attenuation is larger than 80 decibels at any frequency beyond 1 kilocycle from either cut-off frequency.

Figure 13 shows the attenuation curve for a filter of this type, the completed unit being shown in Figure 14.

4.2 PILOT-SELECTING FILTER FOR SINGLE-SIDEBAND RADIOTELEPHONY

A very narrow band is required for the pilot-selecting filter of a single-sideband radiotelephone receiver so that the noise level at the input of the pilot amplifier will be very low. Consequently, this filter must have high frequency stability. Very-low-temperature-coefficient quartz crystals have been used for this purpose. This filter is made of two Jaumann type sections, each equivalent to a lattice network section. Each arm is a dipole of the type shown in Figure 15 and is made of a quartz crystal. The electrical circuit is given in Figure 16.

Figure 17 shows the attenuation curve measured at 20 degrees centigrade; values at 50 degrees are practically the same.

This filter is of type III.2 of Table 1 and is shown in Figure 18.

4.3 LATTICE SECTIONS HAVING TWO CRYSTALS IN EACH ARM WITH EQUAL SERIES INDUCTANCES

A lattice section of type I.5 of Table 1, having two crystals and equal inductances in each arm,

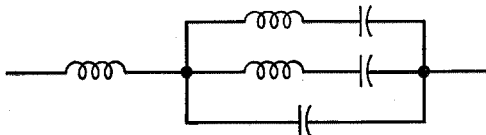

Figure 19—Equivalent circuit for the arm of a lattice section of type I.5.

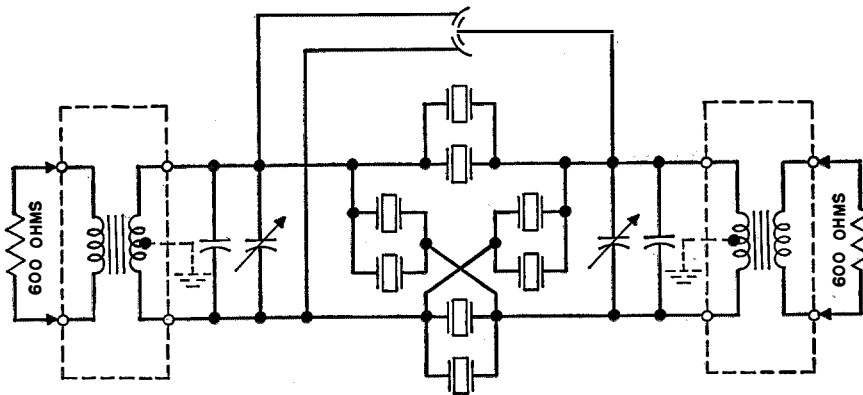

Figure 20—Lattice section having two crystals and equal series inductances in each arm, type I.5.

has the same number of attenuation poles at finite frequencies as two sections of type I.3 as used in the channel filters described above. At infinite frequency, it has only one pole, whereas two sections of type I.3 have two poles.

Figure 19 shows the equivalent circuit for an arm of such a section and Figure 20, the practical arrangement. The series inductances in each arm are made of terminating - transformer leakage inductances. The advantage of this type of section is a reduction in the number of components over two sections of type I.3. Greater accuracy is required in the manufacture of the crystals, however, and factory routine is practicable only for large-scale production.

Figure 21 shows the attenuation curve measured for this section and the unit may be seen in Figure 22.

#### 4.4 APPLICATION

An opportunity has not been had to use this procedure in designing a filter that has a smooth image impedance in the transmitted band. However, this method may be used with advantage for calculating the elements of channel-group filters, such as those used for separating a group or a supergroup of channels in coaxial-cable systems as would be required in through-group or through-supergroup interconnecting equipment.

### 5. Additional References

W. P. Mason, "Electrical Wave Filters Employing Quartz Crystals as Elements," *Bell System Technical Journal*, v. 13, pp. 405-452; July, 1934.

T. Laurent, "Calcul Général Affaiblissements des Filtres à l'Aide des Transformations Fréquentielles," *Ericsson Technics*, v. 5, n. 4, pp. 87-103; 1937.

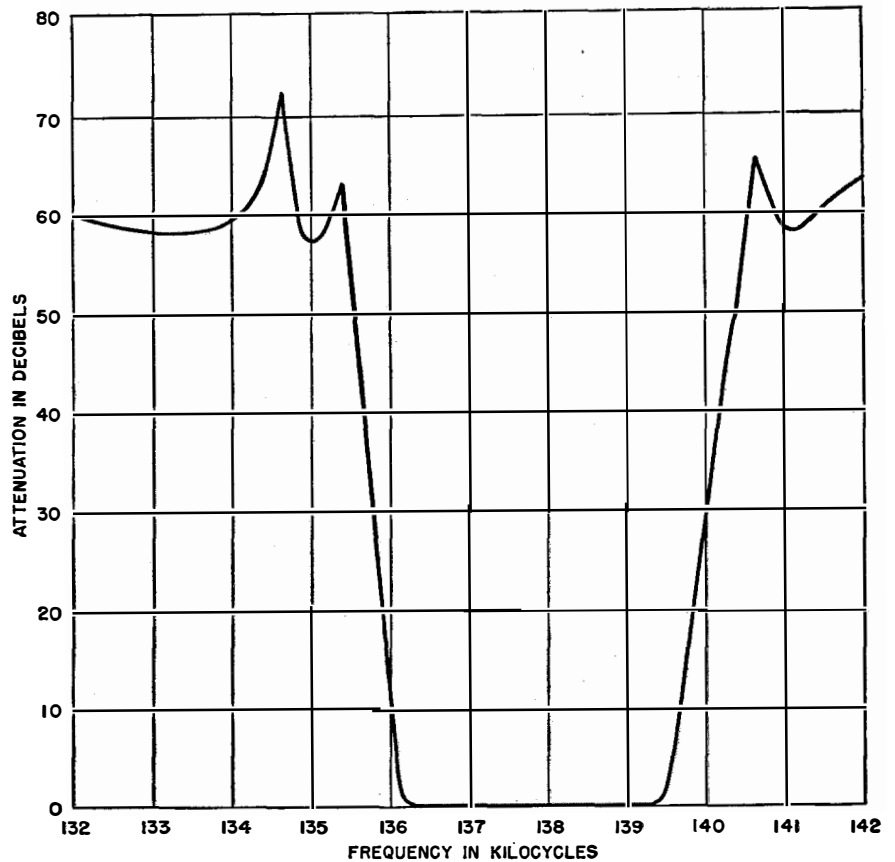

Figure 21—Attenuation characteristic of filter of type I.5.

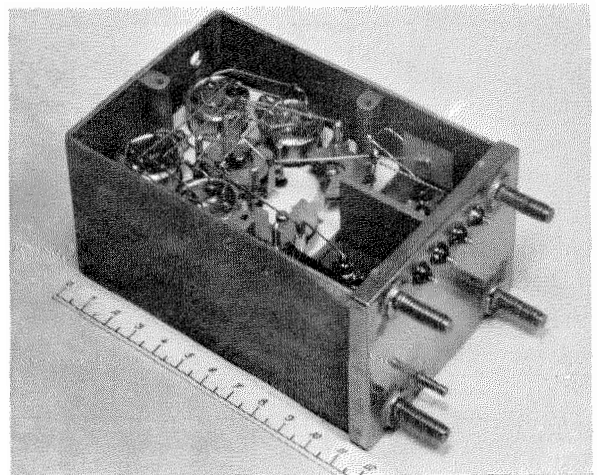

Figure 22—Type I.5 filter.

# Influence of Signal Imitation on Reception of Voice-Frequency Signals\*

By T. H. FLOWERS

*Post Office Research Station, London, England*

and D. A. WEIR

*Standard Telecommunication Laboratories, Limited, London, England*

**S**IGNAL IMITATION is the term used in telephony to describe the operation by speech currents of voice-frequency signalling equipment. There are means by which signal imitation can be reduced to any desired extent, and eliminated when necessary, at some sacrifice of simplicity of the equipment and of signalling speed. The paper is concerned with analysing the means of reducing signal imitation so that a judicious choice of signals may be made. It is based largely on work undertaken in connection with the standardization by the C.C.I.F. (Comité Consultatif International Téléphonique) of a voice-frequency signalling system for international telephone circuits.

The work was primarily directed towards discovering the signalling frequencies least liable to signal imitation. It was found that these frequencies depended on the origin of the speech currents, commercial microphones and telephone circuits giving results very different from high-quality recordings. The effect of language is small compared with that of other variables. Mainly on the evidence of these results, recommendations were made by the 8th Commission de Rapporteurs of the Comité Consultatif International Téléphonique to use frequencies between 2000 and 2500 cycles per second for international signalling in Europe.

The work was then extended to collect data on the influence on signal imitation of factors other than frequency and language.

. . .

## 1. Introduction

Telephone transmission circuits have to be capable of transmitting not only the speech currents that are the prime reason for their existence, but also signalling currents that are

\* Reprinted from *Proceedings of the Institution of Electrical Engineers*, v. 96, Part 3, pp. 223-235; May, 1949.

essential to the rapid interconnection and control of the speech circuits. It follows that the terminal equipments must also be capable of handling speech and signals without mutual interference, or, if interference by one or the other does occur, the effects must be unimportant. In modern practice, speech transmission by the ordinary means of telephony needs a bandwidth some 3 to 4 kilocycles per second wide, and a maximum power handling capacity of the order of one milliwatt. For signals, a bandwidth of 100 to 200 cycles usually suffices even for dialling; the power required depends upon the type of equipment in use. If the speech and signalling frequency bands can be located in different parts of the transmitted spectrum, or in separate circuits, or if the signalling can be allowed for its operation much more power than is produced by speech currents, then independence of the speech and signals is a simple matter.

It is unusual, however, for the circuits employed in long-distance telephony to be able to transmit a band of frequencies wider, or to have a power-handling capacity greater, than that necessary for commercial speech. The signalling frequencies must, in these circumstances, be contained within the speech band and the signalling is then known as voice-frequency signalling. The signalling power cannot be greater than the maximum speech power, nor is there a minimum speech power below which the signals might be transmitted and recognized. Mutual interference between speech and signals using the same transmission circuits can then no longer be avoided by making use of differences in frequency bands or power levels, and the risk is introduced that speech may be mistaken for signals. It is the reduction of this risk to small proportions for some signals, and to zero where this degree of protection is necessary that is the subject of the paper.

It is apparent that as discrimination between speech and signals cannot be accomplished wholly by frequency or power, use must be made of some other characteristic difference or differences. The differences universally employed are concerned with the facts that speech currents, if they contain a signal-frequency component, usually have components at other frequencies also, and that signal currents can be made to have durations longer than the persistence of signal-frequency components in speech currents. In addition, signals composed of two frequencies are often used as being less liable to occur in speech than one particular frequency, and the need to derive a number of different signals usually results in sequences of not more than two pulses which, because they are naturally less likely to occur in speech than a single pulse, incidentally contribute to the safety from speech operation.

The investigation described was limited in scope to the devices and sequences outlined above. Other devices are known and some have been used; for example, making each signal a different number (greater than five) of simple frequency pulses that have to be correctly counted within a given time, and making each signal four or more short pulses of different frequencies, both produce signals that can be readily distinguished from voice currents. Although for this reason these devices might appear attractive at first sight, they appear less attractive when simplicity, cost and reliability of the equipment, and speed of signalling are taken into account. There is no doubt that if signals composed of one or at most two short pulses of signalling current can be plainly recognized by their frequencies, and adequately distinguished from speech currents with a minimum of other aids, the signalling equipment is reliable, relatively cheap, and well able to meet present and anticipated future demands for trunk-line signalling. It was this type of signalling system that was under consideration when the tests described were conceived.

## 2. Terms and Definitions

The basic principles and much of the nomenclature of the subject under discussion have been given in previous publications.<sup>1,2</sup> The terms and

definitions given in this section are limited to those essential to the understanding of the paper.

*Simple signals* are those that consist of only one frequency.

*Compound signals* are those in which more than one frequency is transmitted at a time. Here, compound signals of more than two frequencies are not considered.

*Two-pulse signals* are those that comprise two pulses, either of which may be simple or compound signals, transmitted in time sequence.

A *signal receiver* accepts voice-frequency line signals and converts them to corresponding direct-current signals.

*Signal imitation* is the response of a receiver to speech or other currents that are not genuine signals. It is known that signal imitation may be greatly reduced by designing the receiver to tend to respond to currents of frequency lying within narrow bands centred on the signal frequencies, and to tend not to respond if some or any other frequency occurs at the same time as a signal frequency or frequencies.

A *signal circuit* is that part of a receiver that tends to cause response of the receiver.

A *guard circuit* is that part of a receiver that tends to inhibit response. Genuine signals strongly excite the signal circuit or circuits, but excite the guard circuit only weakly or not at all, and thus the receiver is able to respond. Most speech currents excite the guard circuit more strongly than the signal circuit or circuits, and hence do not cause signal imitation; but it has not yet been found possible in practice to design the signal and guard circuits so that they alone entirely prevent signal imitation. The number of occasions on which signal imitation will occur in a given time is decreased as the sensitivity of the guard circuit increases.

There are severe practical difficulties in defining the sensitivity of the guard circuit in such a manner as would apply to all designs of receiver. This is because, firstly, in any one design the guard circuit may have different sensitivities at different frequencies, and between different designs there is no uniformity; secondly, there are two methods of using the guard-circuit output, and their guarding effects may be different.

<sup>1</sup> Numbered references will be found on page 337.



In one method the output may operate, for example, a relay that negatives the effect of the signal circuit, whatever the output of that circuit, and in the second method the guard-circuit output may be simply subtracted from (or compared with) the output from the signal circuit, and the response of the receiver made to depend on the difference. Only the difference method was used in this investigation.

*Guard coefficient* is the term used in this paper to indicate the sensitivity of the guard circuit and is defined arbitrarily as the ratio of two voltages at the input to the receiver, the first voltage having the frequency of maximum sensitivity of a signal circuit and magnitude within the range of received signal levels, and the second voltage having the frequency of maximum sensitivity of the guard circuit outside the signal frequency bands, the two voltages being such that their combined effect is to produce in the signal relay a current that is the mean of its operate and release currents.

*Critical ratio and guard ratio* have been used during the progress of the work and in reports submitted to the Comité Consultatif International Téléphonique to define the sensitivity of the guard circuit in a slightly different way from the one just given, but these definitions have been found to be less satisfactory. In case there should be some confusion caused by so many terms, a more detailed explanation of them and their relationship to one another is given in Section 11.

*Signal interference* is said to occur when the response of a receiver to a genuine signal is distorted, or completely prevented, by speech or other currents occurring at the same time, or nearly the same time, as the signal currents and thus energizing the guard circuit. The sensitivity of the guard circuit, therefore, tends to become a compromise adjustment between signal imitation and signal interference, and hence the guard circuit is unable to effect complete protection against signal imitation.

*Signal distortion* is the difference between the time during which a receiver relay is operated by a signal and the time duration of the signal. The relay can be operated with varying degrees of

distortion and maintained operated by currents covering a range of frequencies on either side of the nominal frequency. In many receivers there is on each side of this frequency range another band of frequencies over which the relay may be transiently operated or, once operated, may be maintained operated.

*Signal circuit bandwidth* is defined as that range of frequencies over which the relay may be operated and maintained operated.

In practical receivers the bandwidth and the distortion are liable to depend on the level of the input signal and on whether simple or compound signals are being received. It has to be ensured that over the range of received levels there is sufficient bandwidth to cover variations in signal frequency and in the filter or tuned circuit elements of the receivers, and to avoid excessive time distortion of the signals when these other factors are adverse. This invariably means that the signal relay can be operated by inputs at the signal frequency of level below, and often much below, the lowest received signal level. The contraction of the bandwidth and the increase of distortion that occurs at these low levels is of no consequence to signalling. The fact that the relay can be operated is, however, quite important to signal imitation, although its precise effect is dependent on the design of the receiver.

*Signal circuit sensitivity* is defined as the lowest level of any simple frequency that is able to operate the corresponding signal relay irrespective of bandwidth, distortion, and compound operation.

It is always desirable that the guard-circuit voltage should build up quickly. It is sometimes inherent in the design of the receiver that the voltage should die away slowly to achieve the signalling performance, and slow decay is often provided with the intention of reducing the signal imitation. The decay voltage is usually exponential and was so in the equipment described in this paper.

*Hangover time* is the time-constant of this exponential decay.

*Delay time* is delay introduced by a relay or other means after the signal relay operates and before the signal becomes effective. Although

delay time has other uses its only interest here is the reduction it produces in signal imitation. In this respect it has an important bearing on the operation in voice-frequency signalling systems, which results in the interruption of the connection on the exchange side of a receiver, and is designed to confine signals to the circuits for which they are intended.

*Splitting* is the term given to this operation. As no effective signalling results from this operation, signal imitation causing false splitting is important only to speech transmission. Although a surprising amount of false splitting can take place before there is any noticeable effect on speech intelligibility, delay time such as to reduce false splitting to well below the noticeable level is usually used.

*Splitting time* is the term given to this delay. There is at least a further delay time before any effective signalling takes place, and it is the signal imitation of this effective signalling that has the more importance.

### 3. Planning of Investigation

#### 3.1 PREVIOUS WORK

In 1938, the Comité Consultatif International Téléphonique adopted 600 and 750 cycles for signalling<sup>3</sup> on international telephone circuits in Europe. A signal-imitation investigation, which has been described in a previous paper,<sup>1</sup> was made by the British Post Office and telephone equipment contractors in 1938, using commercial signal receivers of a variety of designs and the frequencies 600 and 750 cycles. This work was contributed to the Comité Consultatif International Téléphonique for discussion of the signal times and code for international working at the September 1939 meeting, which was not held due to the outbreak of war. The experience of these prior tests had shown that commercial receivers constructed to satisfy a signalling performance specification and to have adequate manufacturing tolerances, were liable to vary so widely in their signal-imitation properties as to render them quite unsuitable for analysing the effects of different variables in signal imitation. Hence for the contemplated investigation, apparatus much more elaborate than a commercial receiver was

conceived to be necessary, but it may be remarked here that as a result of the work, it is now possible to design receivers that are very uniform in their signal-imitation properties without sacrificing either signalling performance or ease of manufacture. It was also known from tests over a number of years previously, that signal imitation is largely confined to a very small proportion of speakers, and to their manner of speaking. A few speakers reading a set passage or making up conversation will not necessarily produce the range of speech currents that a much larger number of speakers, unconscious of the fact that they are being observed, will produce.

#### 3.2 NEED FOR NEW INVESTIGATION

It soon became apparent after the conclusion of hostilities in 1945 that in several European countries participating in the Comité Consultatif International Téléphonique a change in opinion had occurred during the war, and there was considerable support for higher frequencies to be used for international voice-frequency signalling, chiefly because signal imitation appeared to be less at the higher frequencies up to 3400 cycles, which modern circuits are capable of transmitting.

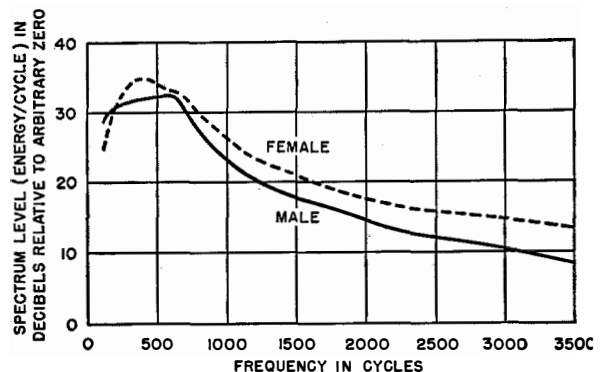

Figure 1—Spectra of normal speech.

Theoretical arguments in favour of using higher frequencies for signalling were based on such evidence as the known spectra of normal speech, e.g. Figure 1, due to Loye and Morgan,<sup>9</sup> which is modified by the characteristics of many commercial telephone transmitters, e.g. Figure

2, which shows the output for different frequency and level inputs of a microphone in wide use in this country. These arguments are proved here to be partly, but not wholly, true, but could not be accepted without practical demonstration for

function of frequency and hence a fair comparison is made by assuming the same receiver sensitivity at all frequencies. In a signalling system using only short signals, the signalling power, if limited by cross-talk considerations, is a function of frequency, and for a fair comparison the receiver sensitivity should be increased by the same amount as the transmitted level has to be reduced. Voice-frequency signalling in Europe contemplates the use of short signals, so that it was by no means certain that any decrease in signal imitation, consequent upon the use of higher frequencies, would be greater than the increased signal imitation liable to occur owing to having to use more sensitive receivers.

A third effect arises out of the modern practice of connecting voice-frequency receivers on the receiving channels of 4-wire circuits with buffer amplifiers to protect the receivers from near-end speech and other disturbances while signalling is taking place. When signalling is not in progress near-end speech can, however, reach the receivers round the echo-path which includes a 4-wire/2-wire terminating set, the loss across which varies considerably with frequency and tends to be least at the two ends of the transmitted frequency band. The echo-path speech at the receiver input therefore tends to be distorted in the direction of accentuating the highest (and lowest) frequencies, with, as was afterward proved, an increased tendency to signal imitation at those frequencies. Signal imitation by echo-path speech and having the effect of merely splitting the connection is of no consequence; the receiver then acts as an echo suppressor. Imitation of complete signals by the echo-path speech is, however, as important as imitation by direct-path speech.

In view of the uncertainties in the evidence and the doubts expressed whether the signalling frequencies already chosen for international working were the best from the point of view of signal imitation, it was decided to submit the question to practical trial and to make the investigation comprehensive enough to provide in addition data that would be useful to receiver designers.

### 3.3 VARIABLES INVOLVED IN SIGNAL IMITATION

The variables having an effect on signal imitation are at least the following:

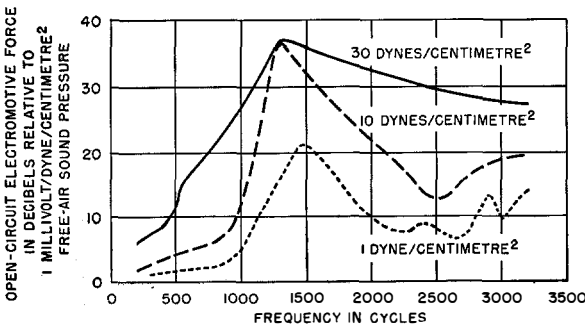

Figure 2—Variation of telephone transmitter output with frequency.

a number of reasons. First, if the probability of signal imitation by speech is extremely small, as it must be in any practical system, the possibility could not be neglected that such imitation as does occur is the result of rare sounds in speech or of the idiosyncrasies of particular speakers, and on these matters there is no evidence. Secondly, it appeared that as the signalling frequency was increased, it might be necessary because of cross-talk on carrier systems to reduce the transmitted signal level. In this connection recommendations were later made,<sup>4</sup> at the Plenary Meeting of the Comité Consultatif International Téléphonique in Montreux, October 1946, that the root-mean-square power of any signal should not exceed the following limits when measured at a zero-level point:

Frequency in Cycles	Power (Root-Mean-Square)
Up to 1600	1 milliwatt
2000	3 decibels below 1 milliwatt
2400	6 decibels below 1 milliwatt
2800	12 decibels below 1 milliwatt
3200	12 decibels below 1 milliwatt

This recommendation has to be borne in mind when assessing the relative liability to signal imitation of signals at different frequencies. In a signalling system in which the transmitted power is limited only by the loading of multi-channel amplifiers, such as in systems using long or repeated signals, the signalling power is not a

- A. Characteristics of the speech currents offered, comprising chiefly the attenuation distortion of the transmission system, and language.
- B. Signal frequency or frequencies.
- C. Signal-circuit sensitivity.
- D. Signal-circuit bandwidth.
- E. Guard-circuit frequency characteristics.
- F. Guard coefficient.
- G. Hangover time.
- H. Delay time.
- J. Simple and compound signals.
- K. Sequencing of signal pulses (two-pulse signals).
- L. Characteristics of signal receivers.

It was clearly impossible to explore all the many combinations of so many variables, and it was not considered essential to do so. It seemed justifiable to assume that the effects of all the variables except *A*, *B*, *E* and *L* were obvious qualitatively. Variable *E* was eliminated somewhat arbitrarily by making the guard circuit uniformly responsive to all frequencies outside the signalling band.

Discussion of the question of the characteristics of signal receivers would be too lengthy to include here. Briefly, receiver designs fall into three main classes depending on the method employed to ensure more or less distortionless operation over the received signal level, which level may vary as much as 20 decibels and is a major problem in design. In one of these classes limiters are used to reduce all signals to a constant level; in the second, the same result is obtained with constant-volume amplifiers. In the third of these classes, the signal and guard circuit output voltages are strictly proportional to the input voltages (the guard voltage building up quickly and dying away slowly), and impulsing substantially independent of the input level is secured by making the receiver relay operation dependent on a comparison between the signal and guard circuit voltages. It was a receiver of this class that was under contemplation when this investigation was planned. It is the easiest one to specify in all its characteristics and construct with some degree of precision. It is further likely that results obtained with this class of receiver differ only in degree from those found using other classes of receiver. It was decided for these reasons to adopt this class of receiver for investigation, and thus to eliminate the characteristics of receivers as a variable.

The problem therefore resolved itself into planning a series of experiments that would first explore the unpredictable variables *A* and *B*, and, second, enable the effects of the remaining variables to be confirmed and assessed quantitatively.

### 3.4 STAGES IN THE INVESTIGATION

The investigation was carried out in three stages. In the first stage, English language from two sources, working trunk circuits and high-quality recordings, was used, and the number of times that signal imitation exceeded a series of delay times was measured with frequency and signal circuit sensitivity as the main variables, and guard coefficient and compounding of frequencies as subsidiary variables. These tests covered a considerable number of combinations of the variables and took several months to perform. The results showed the important fact that the frequencies least liable to signal imitation depended on the characteristics of the speech offered, but not on any other variable except to a minor extent on whether simple or compound frequencies were used. This fact simplified much of the succeeding work.

The object of the second stage of the investigation was to examine the effect of language on imitation. Through the courtesy and with the co-operation of the Posts, Telegraph and Telephone Administration of Switzerland, the test equipment was installed in Zürich trunk exchange where speech currents in German, French, and Italian languages are readily available. In addition the administrations in Czechoslovakia, Denmark, Holland, Hungary, Norway, Sweden, and Switzerland contributed high-quality records of speech in their own languages, and Portugal records of trunk-line speech in Portuguese. They were tested in Zürich.

These tests showed that language did not affect the choice of frequencies for minimum signal imitation. At this point, making use of the results of this investigation and work in other countries, the 8th Commission de Rapporteurs of the Comité Consultatif International Téléphonique made recommendations concerning the signalling frequencies for international working; all further tests, which comprised the third stage in the investigation, were made with these fre-

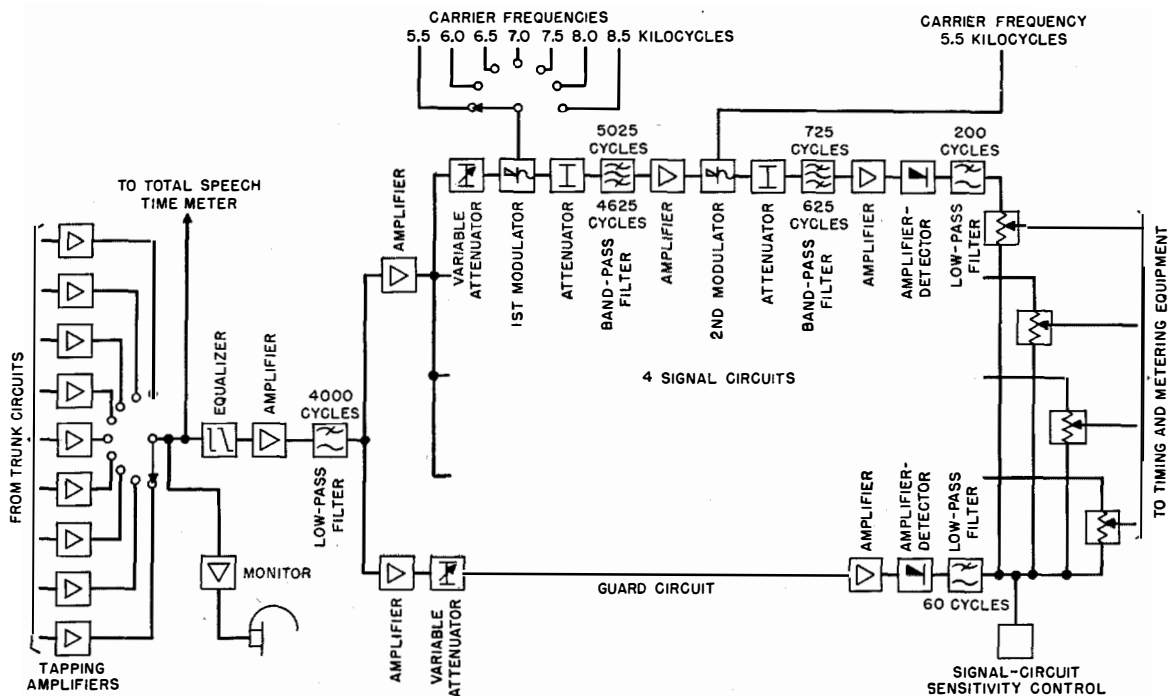

Figure 3—Schematic of test apparatus

quencies and with the testing apparatus conforming to the specification for receivers drawn up at about this time by the 8th Commission de Rapporteurs.<sup>5</sup>

In the third stage quantitative data on all the variables except frequency were obtained. These data apply to the agreed frequencies and signaling conditions for international signalling, but not necessarily to other frequencies and conditions that administrations might choose to use for a variety of reasons in their national systems. The data are a valuable guide in these cases, but the whole field was not covered on account of the enormous labour of compilation and the uncertainty as to whether the results would be used.

#### 4. Test Equipment and Procedure

A schematic diagram of the equipment used for the first and second stages of the investigation is shown in Figure 3. The modifications for the third stage are given later. It is not proposed to detail the circuit operation at this point as the salient features are described in later sections.

The following characteristics are however worthy of special emphasis:

- A. The bandwidth for all frequencies tested was identical and substantially independent of guard coefficient.
- B. Signal circuit sensitivity could be adjusted to within 1 decibel of its nominal value, but the effective accuracy was mostly the accuracy of the overall loss of the trunk circuits to which the equipment was connected. The bandwidth at the threshold of sensitivity was substantially the same as at higher levels.
- C. Guard coefficient was accurate to about 1 per cent.
- D. The hangover time approached zero, being limited only by the 60-cycle filter necessary for smoothing the rectified guard-circuit output.
- E. Delay times were accurate to 1 millisecond.

The equipment, which included over 1200 valves, was mounted on four self-supporting racks, with a fifth rack containing the power supplies. This somewhat elaborate provision of equipment was justified by the results, as only by great care and attention to detail could the effects of the variables involved be elucidated convincingly enough to resolve the many questions on which differences of evidence and opinion existed.

## 4.1 SOURCES OF SPEECH CURRENTS

### 4.1.1 *English Language*

The equipment was initially located at London Trunk Exchange where it was connected to the 4-wire receiving side of nine working long-distance circuits, a number being utilized rather than one in order to increase the number of speakers' voices tested in a given time. The trunk circuits chosen for the purpose of the tests were carrier circuits conforming to Comité Consultatif International Téléphonique recommendations for international working and having an overall loss of 3 decibels. They were equipped with blocking amplifiers to protect the equipment from near-end speech only when it was desired to determine the effect of such amplifiers. Speech from any one of the nine circuits could be directed into the testing equipment via a tapping amplifier selected by a switch, selection of a particular circuit being dependent upon there being speech on that circuit. This arrangement is shown in Figure 3. It was later superseded by an automatic selecting amplifier performing the same function without operator assistance. The total time that active speech circuits were connected was automatically recorded. In this way tests were made of the speech currents as they now occur on the British inland trunk system.

High-quality speech currents were obtained in the first place from recordings of radio broadcast programmes, kindly loaned for the purpose by the British Broadcasting Corporation and subsequently supplemented by recordings made by the Post Office of British Broadcasting Corporation programmes. The equipment used for reproduction from the records was designed so that the overall characteristics from recording to playback was sensibly uniform up to 4 kilocycles (the cut-off frequency of a low-pass filter in the input to the signal imitation test equipment). The level of the output from the play-back unit was adjusted until its mean value was the same as that observed on the long-distance circuits, equality being assessed, as nearly as it could be, by means of a speech voltmeter.

The recordings were taken at random, subject to two restrictions:

- A. Recordings including sounds other than speech (e.g. incidental music) were excluded.
- B. Not more than 5 minutes' recording of any one speaker was included.

Many of the recordings used contained a number of different speakers' voices within the maximum playing time of 5 minutes, so that the number of different speakers' voices sampled during one hour's testing on high-quality speech was of the same order as in the tests on working telephone circuits.

Some of the recordings (particularly those of the sound accompanying television broadcasts) were not of continuous speech, but included silent intervals. The play-back unit was therefore connected to one input of the automatic selecting amplifier, the other inputs being disconnected, and recordings played until the total speech time meter recorded 1 hour. In this way the duration of tests, whether on high-quality speech or on working telephone circuits, was measured in substantially the same manner.

### 4.1.2 *Other Languages*

When the tests made in England were repeated in Zürich, the same precautions as regards variety of speakers and speech material were taken as far as possible. There was not, however, as much recorded speech in the various languages as in England, nor would it have been possible to test so many languages at such length. Allowance must therefore be made for the results not reaching the same degree of stability.

## 4.2 SIGNAL CIRCUITS

The part of the test equipment designed to compare the relative liability to signal imitation of different frequencies used for the signals, comprised four signal circuits, all identical in construction and each including two modulation and filtering stages in series so that, by the selection of the appropriate carrier frequency for the first modulator, any one of the signal circuits could be made to select a band of frequencies about 100 cycles wide and centred on any of the frequencies 675, 1175, 1675, 2175, 2675, 3175, 3675 cycles. The choice of the first of these frequencies was governed by the need to avoid 500, 600, 750 and 900 cycles which are all in use on the British trunk system for signalling; the remaining frequencies followed from the need to choose convenient carrier frequencies. The amplified outputs from the filters following the second modulators were rectified by diodes and

smoothed by filters to produce direct voltages equal to the mean rectified signal-circuit voltages. Great care was exercised to ensure that the output direct voltage was proportional to the input alternating voltage over the full range of input levels.

The attenuation/frequency characteristic of the filter following the second modulation was uniform within 1 decibel over a band of 80 cycles, and at an attenuation 30 decibels greater than the mid-band attenuation, the bandwidth was 125 cycles.

The advantage of this double-modulation method of frequency selecting was that all the test signal circuits were identical. There was therefore no doubt that measured differences in signal imitation at different frequencies were genuine, and not in fact due to the testing equipment. In addition, the test circuits could be used in rotation for each frequency under test, thus allowing the errors to be evenly spread, and any fault in one circuit to be shown up by comparison with the results from the others. Tests with all four test circuits set to record under identical conditions confirmed an adequate uniformity in the readings.

#### 4.3 SIGNAL-CIRCUIT SENSITIVITY

A control was incorporated by means of which the minimum-level simple-frequency signal to which the equipment would respond, could be set to any value down to the limit of sensitivity of the signal-circuit detectors, which was about 40 decibels below 1 milliwatt of a zero-level point. The accuracy of the control deteriorated as the limit of sensitivity was approached, for which reason the lowest-level setting of the control which was used was  $-30$  decibels.

In practice the lowest-level received signal is usually about  $-20$  decibels, but signal circuits are often sensitive down to  $-30$  decibels in order to provide the requisite performance at the lowest received-signal level.

All stated sensitivities in this paper are referred to 1 milliwatt in 600 ohms as a point of zero relative level.

#### 4.4 GUARD CIRCUIT AND GUARD COEFFICIENT

In the first and second stages of the tests the guard coefficient was of the aperiodic type, the

response throughout the received frequency band therefore being substantially constant.

A single guard circuit was used for all signal circuits; the transmission delay through the signal circuits and guard circuit was made much the same by provision of a suitable number of sections in the guard-circuit low-pass filter. Variation of guard coefficient was achieved by control of the circuit amplification.

Signal imitation was held to occur, and was recorded, when the rectified signal voltage exceeded the rectified guard voltage.

#### 4.5 DELAY TIME

The durations of the occurrences of signal imitation were measured for each signal circuit. The durations were measured by counting cycles of a 1000-cycle standard frequency (readily available from carrier frequency-generation and synchronization equipment) during the times that signal imitation occurred. The number of occasions on which these durations exceeded a set of predetermined times was then counted on meters, of which there were seven per circuit. The predetermined times could be readily altered.

For recording simple-frequency imitation, arrangements were made for one of the delay-time measuring equipments to start operating when a signal-circuit voltage exceeded the guard-circuit voltage and the signal-circuit sensitivity limit, and to stop when the first of these voltages fell below the second or below the signal-circuit sensitivity limit. For registering compound-signal imitation, delay time was measured and meters operated only so long as two signal-circuit voltages each individually exceeded the guard voltage and the sensitivity limit.

It was expected that cases of signal imitation would sometimes occur very closely together. To record such imitations individually would not necessarily represent the practical conditions where delay time is provided by a slow relay which would tend to integrate closely spaced operations of a receiver relay. For this reason two arbitrary decisions were taken:

A. A gap of less than 20 milliseconds between two periods of signal imitation was ignored, the time of the second period being added to the first. If there was a gap of more than 20 milliseconds, the two periods were treated as

separate cases of signal imitation. This time is called the short delay time.

B. Metering was withheld until a clear interval of 1 second, called the long delay time, had elapsed after a case of signal imitation. A single registration was then made of the longest occurrence of signal imitation since the previous gap of one second.

The short delay time was found to have little effect until it reached a value much greater than the 20 milliseconds at which it was fixed.

The effect of the long delay time proved to be that values of imitations below 100 were virtually unaffected, but at higher values the readings obtained were lower than would have resulted had the delay time been much less than 1 second. The inaccuracies introduced are of little practical importance as only low values of signal imitation would be of interest in any signalling system.

#### 4.6 SIMPLE AND COMPOUND SIGNALS

The two signalling systems of most interest at the time of the investigation were:

A. A single-frequency system in which the first part of each signal represented a prefix, the duty of which was to prepare for the reception of the second and operative part of the signal. In such a system the various operational intelligence is conveyed by controlling the length of the operative portion of the signal or relying upon sequences of signal and absence of signal to afford discrimination.

B. A compound-frequency system in which an operative signal is preceded by a prefix composed of two frequencies, the operative signal being of either frequency and of variable duration which is varied to represent the different signals.

In the first and second stages of the investigation the interest was confined to the prefix portion of the signal only, no results of a complete signal being intentionally sought.

The actual frequencies examined in compound lie fairly close together. Time did not permit tests to be made throughout the complete range of compounding, but there is no evidence to suggest that any advantage would be derived were the two frequencies spaced far apart in the band. Practical considerations of receiver design determine the minimum separation of the two component frequencies.

#### 4.7 ACCURACY OF THE OBSERVATIONS

It has to be appreciated in considering the results of the tests that the values given in the curves as the numbers of cases of signal imitation per speech hour are mean values obtained over a varying number of hours per test condition. The dispersion is indicated in Table 1 where some of the entries consist of up to three numbers. The first number is the mean number of cases of signal imitation per speech hour. Where this is followed by a number preceded by the  $\pm$  sign, the number expresses the limits on either side of the mean as given by the first number within which 95 per cent. of the means of further sets of identical tests could be expected to lie, assuming normal error distribution of the individual readings, i.e. it expresses the 95 per cent. confidence limits. A number placed below one of the means

TABLE 1  
TRUNK-CIRCUIT SPEECH, SIMPLE-FREQUENCY TESTS  
Signal-Circuit Sensitivity = -30 decibels. Guard Coefficient 0.53.

Nominal Frequency in Cycles	Delay Time in Milliseconds							Total Speech Hours
	0	50	100	150	200	250	300	
675	1094±38	302±25	75±8	23±3	8.4±1.2	3.9±0.9	1.8±0.7	29
	97	64	20	8	3.5	2.4	1.8	
1175	1067±47	373±52	99±23	23±8	5.2±1.9	1.7	0.6	12
	71	78	35	12	2.8	1.0	0.6	
1675	866±77	118±34	16±7	3	0.5	0	0	13
	122	55	7	3.4	0.8	0	0	
2175	479±69	34±24	1.5	0.1	0	0	0	11
	98	34	1.8	0.95	0	0	0	
2675	118±22	1.9	0.1	0	0	0	0	11
	31	1.1	0.95	0	0	0	0	
3175	22±9.5	0.1	0	0	0	0	0	11
	13.5	0.95	0	0	0	0	0	



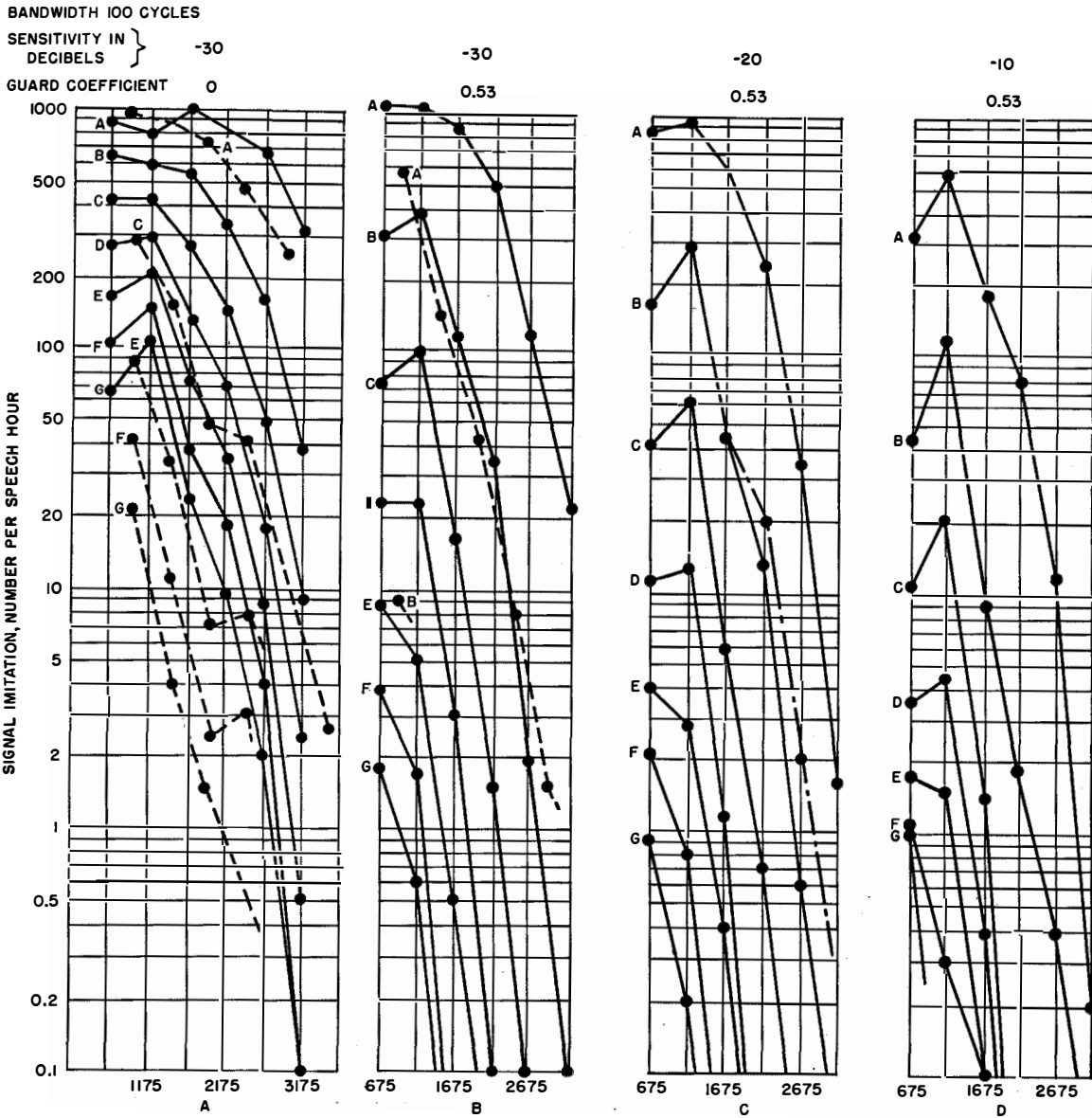

Figure 4—English trunk-circuit speech.

- indicates simple-frequency signals.
- - - - indicates compound-frequency signals.
- · - · indicates level-corrected curve.

Delay time in milliseconds A = 0; B = 50; C = 100; D = 150; E = 200; F = 250; G = 300.

indicates the standard deviation of the observations from which the mean was estimated.

The observations give plots that result for the most part in curves as smooth as can be expected from the character of the measurements. Where the curves are far from smooth, it is apparent that the corresponding meter readings are too low for stability to have been reached in the

readings. The high readings are subject to error due to the arbitrarily chosen long delay time mentioned in Section 4.5.

It must be borne in mind, therefore, in examining the results that those readings below about 5 per hour may be suspect because of insufficient readings to reach stability. Because of the long delay time, readings of about 200 to 300 per hour

are too low to the extent of a few per cent., and those above these figures are increasingly low as the readings increase. It is to be emphasized, however, that the inaccuracies are unimportant to the general conclusions.

## 5. Signalling-Frequency Tests

### 5.1 ENGLISH LANGUAGE ON BRITISH TRUNK CIRCUITS

The curves given in Figure 4 show the more important results obtained from the very considerable number of tests that were made with the equipment described in Section 4 connected to trunk circuits in the London Trunk Exchange. The curves have been drawn by joining with straight lines successive points obtained directly from the meter readings. This has been done because of the difficulty of drawing smooth curves through some of the points. Figure 4A shows the number of imitations of simple signals experienced with various signal circuit frequencies and delay times, when no guard circuit was employed. The curves thus reflect the characteristics of the speech offered. Curves 4B refer to the same conditions as curves A except for a guard coefficient of 0.53. It is to be noted that the signal imitation is greatly reduced but the general tendencies are unchanged. Curves 4C and 4D are the same as 4B except that the signal circuit sensitivities are  $-20$  and  $-10$  decibels respectively. Again there is no significant change in the general shape of the curves. There is a tendency to a maximum at around 1100 cycles and a sharp falling off as the frequency exceeds 2000 cycles. The effect of signal-circuit sensitivity is not sufficient for the required changes in signal level as the frequency increases, as given in Section 3.2, to make any substantial difference to the general effect of frequency. This is shown by the chain dotted curve in Figure 4C which corrects one of the curves for change in signal level. Compound signals do not show a maximum but have otherwise the same characteristics as simple signals. Pairs of adjacent simple frequencies were compounded and typical results are plotted as dashed-line curves in Figures 4A and 4B where the frequency scale refers to the mean value of each of the pairs of frequencies.

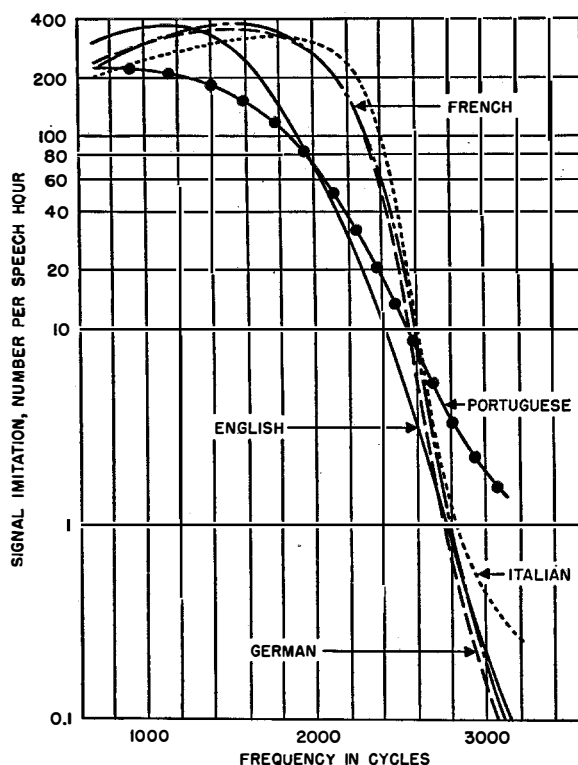

Figure 5—Trunk-circuit speech, simple-frequency signals.

Sensitivity =  $-30$  decibels.  
Guard coefficient = 0.53.  
Delay time = 50 milliseconds.  
Bandwidth = 100 cycles.

### 5.2 FRENCH, GERMAN, AND ITALIAN LANGUAGE ON SWISS TRUNK CIRCUITS

The tests in Zürich confirmed the general conclusions of the English tests, although there was a pronounced difference in the frequency of maximum imitation. This is illustrated in Figure 5 which shows curves for English, French, German, and Italian languages, the first extracted from the London tests and the others from the Zürich tests. It is to be noted that there is far less difference between the curves for the Swiss languages than between those and the English language; this is thought to be due to the different microphones in use in the two countries.

### 5.3 PORTUGUESE LANGUAGE ON PORTUGUESE TRUNK CIRCUITS

The results using records supplied by Portugal of trunk-line speech are plotted in Figure 5. This

curve is also different again from the English and Swiss curves although with somewhat the same general characteristics.

5.4 ECHO-PATH SPEECH

The results given in Sections 5.1 and 5.2 were obtained without buffer amplifiers to protect the measuring equipment from near-end speech, which speech masks the effect of the echo-path speech. Figure 6 shows curves obtained from tests in London with and without buffer amplifiers on the circuits. It will be seen that without guard circuits the signal imitation is less with than without buffer amplifiers, but with a guard circuit the opposite is the case at most frequencies. The explanation of these effects has to do with the signal imitation being made up of two parts, each of which operates for roughly half the observation time. One part is that due to the distant-end speech, i.e., speech from the end of the circuit remote from the receiver, and is unaffected by the presence of a buffer amplifier. The other part is that due to the near-end speech which is effectively direct without a buffer amplifier, but with a buffer amplifier has to take the echo-path to reach the receiver.

With a guard circuit it will be seen that up to 2000 cycles the difference caused by buffer amplifiers is small, but the difference increases as the frequency increases above that value. From all the readings obtained under various conditions, it appears that from about 2500 cycles upwards, the imitations of a simple signal are 5-10 times as numerous with the buffer amplifiers as without them. Hence with buffer amplifiers most of the recorded cases of signal imitation must be due to the echo-path speech, and as this operates for roughly only half the speech time, the echo-path speech must be about 10-20 times more liable to produce signal imitation than the direct-path speech.

This result is of some importance at the present time and is a factor weighing against the use of high frequencies. It is likely to be of diminishing importance as four-wire switching with individual line balances comes into operation. The attenuation distortion across the terminating sets is then reduced. The effect is of diminishing importance also as the overall loss of the trans-

mission path between the terminating sets is increased, since the echo-path attenuation increases at twice the rate and tends to reduce the chances of signal imitation. It is the practice of many countries to have more loss in their trunk circuits than the 3 decibels of these tests, and 4-wire switching will tend to encourage an increase in the losses in the echo paths.

On the whole, it may be concluded that echo-path speech is not likely to be a very important factor in the future; even now it has no great effect at frequencies up to 2000 cycles.

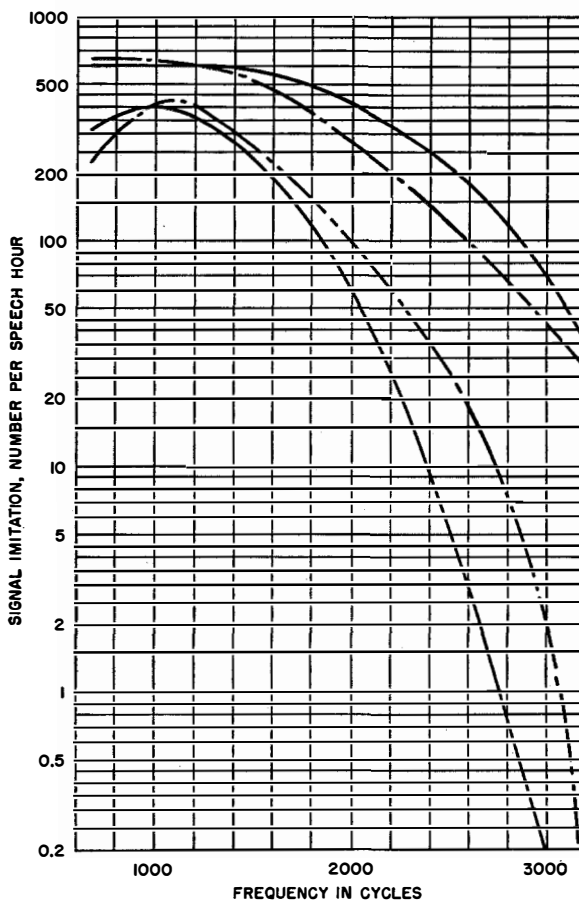

Figure 6—English trunk-circuit speech—effect of echo path on simple-frequency signals.

— — — with buffer amplifier.  
 ————— without buffer amplifier.  
 Bandwidth = 100 cycles.  
 Sensitivity = -30 decibels.  
 Delay time = 50 milliseconds.

Guard coefficient for 2 upper curves, 0;  
 for 2 lower curves, 0.53.

## 5.5 HIGH-QUALITY SPEECH

High-quality speech was exhaustively tested in English to confirm, as for the trunk-line speech, that there was no ambiguity in the indication of the best choice of signalling frequency as given by various combinations of the variables.

Selected results of imitations of simple-frequency signals by European languages including English are shown in Figure 7. The curves are all quite different from those obtained with trunk-line speech, having no maximum but tending to a minimum at about 2500 cycles. Hence the high-quality speech indicates that there is considerable advantage in using a signalling frequency as high as possible, up to 2500 cycles, whereas the trunk-line speech shows that there is little advantage up to, but considerable gain above, 2000 cycles.

It is concluded that the effect of language on signal imitation is insufficient to affect the choice of signalling frequency. From the curves of Figure 7 it appears that language has no effect up to about 2000 cycles, but it seems that the differences above that frequency are too great to be wholly accounted for by the instability of the observations. These tests, coupled with the fact that the curves for French, German, and Italian languages all tested on the same network give almost identical results, suggest that the curves of Figure 5 reflect more

the differences in the characteristics of the microphone and transmission circuits than the differences in language.

Figure 1 compared with Figure 7, and Figures 1 and 2 combined compared with Figure 5, suggest that signal imitation is only slightly dependent upon the spectra of speakers' voices when the transmission system is free from attenuation distortion, but should the transmission system include such distortion, signal imitation will tend to follow the distortion, increasing where the distortion is such that the signal level is increased and vice versa. The extreme case of attenuation distortion in which a band of fre-

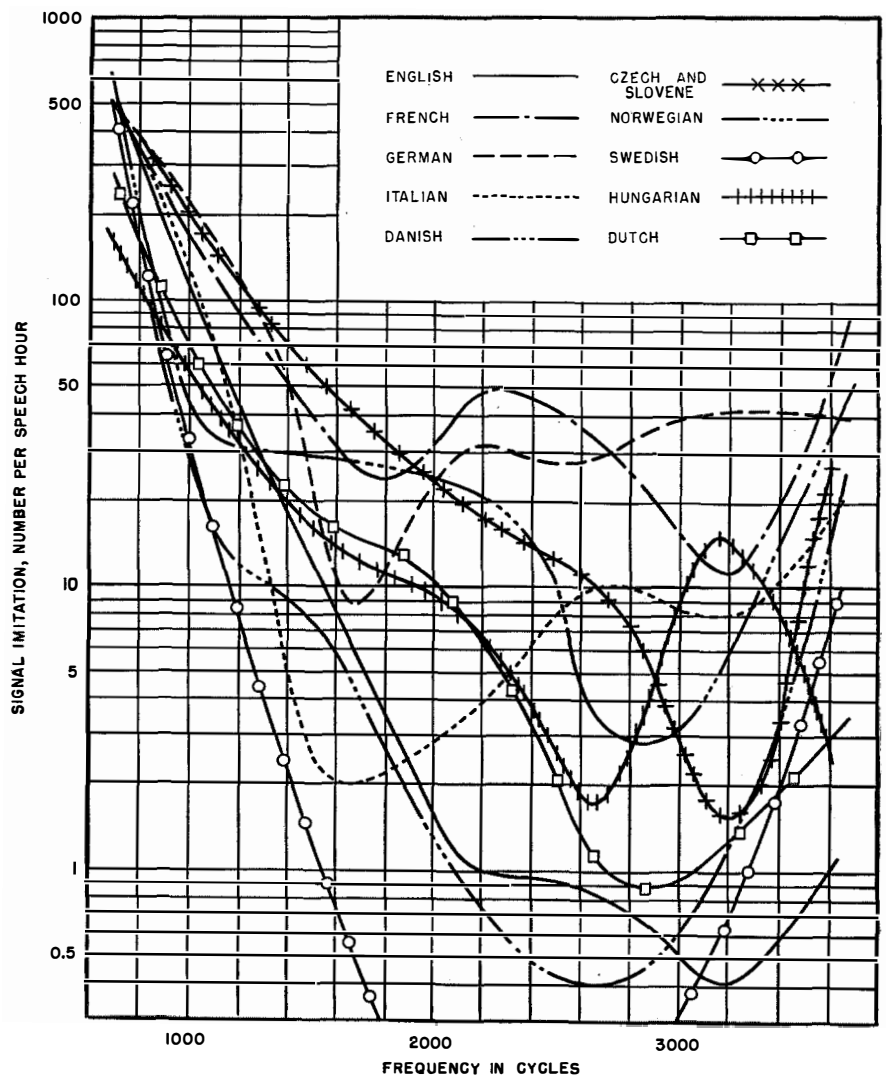

Figure 7—High-quality speech, simple-frequency signals. Sensitivity = - 30 decibels; guard coefficient = 0.53; delay time = 50 milliseconds; bandwidth = 100 cycles.

quencies is excluded from the speech circuit is sometimes used for signalling without risk of signal imitation.

To determine more precisely the causes of signal imitation requires further research which, although contemplated, cannot be discussed here.

### 6. Choice of Signalling Frequencies for International Signalling

The 8th Commission de Rapporteurs of the Comité Consultatif International Téléphonique has recommended<sup>4</sup> the frequencies 2040 and 2400 cycles for international signalling systems using compound signals. (These frequencies are even multiples of 60 cycles in order to fall between the frequencies used for international voice-frequency telegraphy.) For a simple-frequency system a frequency between 2100 and 2300 cycles has been recommended, the actual value to be fixed later. In making these recommendations the 8th Commission de Rapporteurs was greatly influenced by the fact that a substantial portion of the international circuits now existing, and expected to remain for some considerable time, cannot be relied upon to transmit frequencies any higher than 2400 cycles without considerable attenuation distortion. The simple frequency chosen is not so very much preferable to one using lower frequencies so long as the present microphones persist, but will become increasingly favourable as newer microphones with a more uniform frequency response are introduced. Compound signals have an immediate benefit from the new frequencies.

### 7. Voice-Frequency Receiver Tests

For the second stage in the investigation, the equipment described in Section 4 was modified so that it had the characteristics of a voice-frequency receiver to the Comité Consultatif International Téléphonique specification<sup>5</sup> drawn up at the same time as the frequency recommendations were made. The modifications included substitution of the original signal circuits and guard circuit by others comprising filter networks having as mid-band frequencies 2000 and 2400 cycles for compound signals (2000 cycles was used for convenience instead of 2040 cycles), and 2200 cycles for simple signals. The guard circuit was no longer aperiodic (except fortui-

tously for one value of guard coefficient of 0.53), because high guard coefficients (such as 2) imply an output from the guard circuit so nearly equal to that of the signal circuit that small imperfections in either circuit have a very considerable effect on the real value of the guard coefficient.

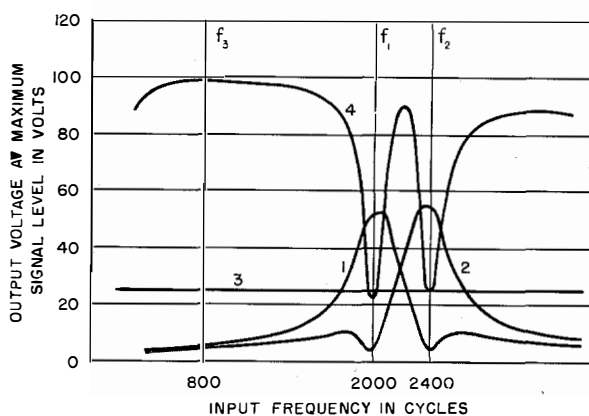

Figure 8—Signal and guard-circuit characteristics.

Guard coefficient = 2.13.

Curves 1 and 2 refer to signal circuits, curve 4 to the guard circuit.

Figure 8 shows the signal and guard-circuit characteristics for a guard coefficient of 2.13. Curves 1 and 2 refer to the signal circuits and curve 4 to the guard circuit, the output of which at 800 cycles was a maximum and was used to calculate the guard coefficient. A further detail was the feeding of a small fraction of the output voltage from each of the signal circuits into the other signal circuit. This has no measurable effect on simple-frequency operation, but is a useful aid to receiver operation to compound signals when the received levels of the two signals have become several decibels different owing to attenuation distortion of the transmission channels.

All the trunk circuits were equipped with buffer amplifiers. Their presence reproduced the present signalling conditions and gave a result that for future conditions is a pessimistic rather than an optimistic one.

The equipment was then used to obtain quantitative data on each of the variables. Speech from trunk circuits terminating in London was used.

## 7.1 SINGLE PULSE SIGNALS

### 7.1.1 Hangover Time

The most careful measurements with hangover times from a few milliseconds to over 200 milliseconds failed to show that signal imitation is substantially affected by hangover time. This was a most surprising result in view of the well-established conviction that long hangover times had the effect of materially reducing signal imitation. The assumption which has hitherto been made is that sounds that are about to cause operation of the receiver relay or relays, are preceded in most instances sufficiently closely in time by sounds that operate the guard circuit, so that the guard voltage or current thus produced, if made to persist, i.e. hang over, can prevent the imitation occurring. As far as is known there is no evidence for this assumption. The results of these tests indicate that the assumption is false.

Hangover time has the effect of prolonging those effects that result in signal interference. In the interests of receiver operation there is thus every reason to keep the hangover time as small as possible.

### 7.1.2 Guard Coefficient

Figure 9 shows the relationship between three values of guard coefficient for simple and compound signals in terms of delay time against the number of signal imitations, the sensitivity being -30 decibels and the bandwidth 100 cycles.

In any system it is clearly desirable to use the highest possible value of guard coefficient. The practical limit to the value of the guard coefficient, which limit is set by signal interference due to noise and other disturbances, and to some extent by design problems, is outside the scope of the paper.

### 7.1.3 Signal-Circuit Sensitivity

Contrary to expectations, signal-circuit sensitivity has only a minor effect on signal imitation. The curves of Figure 4 illustrate the effects when there is only moderate protection against imitation. It was found that as signal imitation was progressively reduced by exploiting the powerful factors of guard coefficient and compound operation, it finally became almost independent of signal-circuit sensitivity and must therefore have been mostly due to loud sounds. This naturally prompted the suggestion that the final residue of signal imitation was not speech but switching clicks or other disturbances occurring very rarely but at considerable power; no confirmation of this suggestion was obtained over many hours of careful monitoring of the tests.

### 7.1.4 Signal-Circuit Bandwidth

Table 2A shows the number of imitations of a simple-frequency signal of 2400 cycles with the test apparatus having bandwidths of 100 and 200 cycles obtained by filters, and a commercial

TABLE 2  
SIGNAL IMITATION PER SPEECH HOUR WITH TRUNK-LINE SPEECH AND BLOCKING AMPLIFIERS  
Signal-Circuit Sensitivity = -30 decibels. Guard Coefficient = 0.53.

A	Bandwidth in Cycles	Delay Time in Milliseconds						Total Speech Hours
		10	20	40	60	80	100	
Simple Frequency 2400 Cycles								
Test Apparatus.....	200	234	138	59	26	12.2	5.8	5 9 104
Test Apparatus.....	100	220	71	35	11.2	4	1.8	
Commercial Receiver.....	200	120	36	9.2	2.5	0.9	0.48	
B								
Compound Frequency 2000+2400 Cycles								
Test Apparatus.....	200	128	69	36	8.6	2.5	0.5	11 20 106
Test Apparatus.....	100	31	13.9	6.5	1.4	0.35	0.10	
Commercial Receiver.....	200	1.56	0.66	0.23	0.09	0.05	0.03	

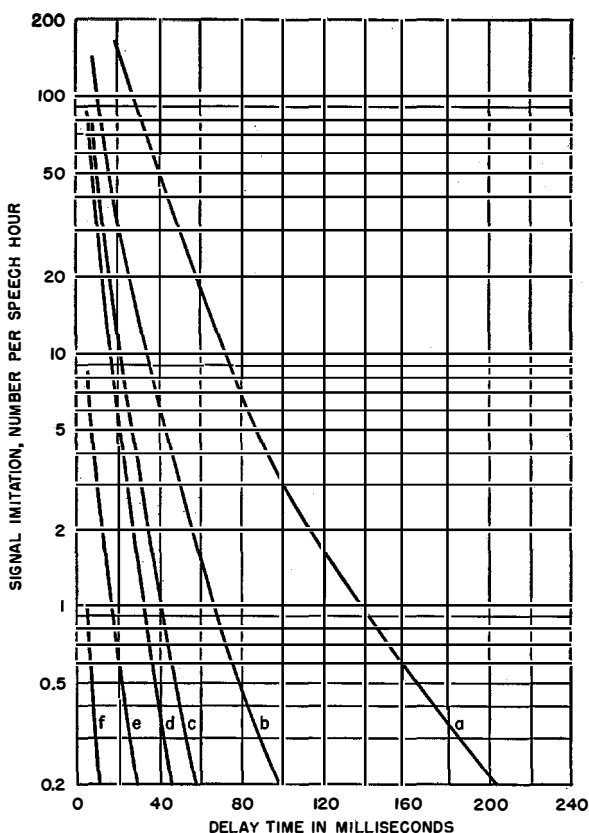

Figure 9—Effect of guard coefficient on signal imitation.

Signal-circuit bandwidth = 100 cycles.

Signal-circuit sensitivity = -30 decibels.

- a Simple frequency 2200 cycles, guard coefficient = 0.53.
- b Simple frequency 2200 cycles, guard coefficient = 1.06.
- c Simple frequency 2200 cycles, guard coefficient = 2.13.
- d Compound frequency 2000 + 2400 cycles, guard coefficient = 0.53.
- e Compound frequency 2000 + 2400 cycles, guard coefficient = 1.06.
- f Compound frequency 2000 + 2400 cycles, guard coefficient = 2.13.

receiver having 200-cycle bandwidth obtained by simple tuned circuits but otherwise having the same parameters and design as the test apparatus. Table 2B shows the number of imitations of a compound-frequency signal of 2000 and 2400 cycles with otherwise the same conditions as Table 2A.

It was anticipated that signal imitation would increase rather more rapidly than the bandwidth increased, and this is largely confirmed. Compound signals appear to be more affected by bandwidth than simple signals. Signal imitation with the commercial receiver is remarkable in

being less than with the test apparatus under the same nominal conditions. This is no doubt due in part, if not wholly, to the use of tuned circuits instead of filters. With the outputs at the signal frequency arranged to be equal in the two cases, and the signal-circuit bandwidths also equal according to the definition, tuned circuits have a smaller output compared with filters over the remainder of the bandwidth, and illustrate the difficulties of defining the quantities involved.

### 7.1.5 Compound Frequency

Figure 9 indicates that, other things being equal, the delay time with compound signals need be only about one-fifth that with simple signals; or alternatively, the number of imitations with compound signals is only one-hundredth that with simple signals. These figures are very approximate but there can be no doubt about the very great advantage of compound over simple signals in respect of signal imitation.

### 7.1.6 Delay Time

Delay time does not affect the design of the voice-frequency receivers. It is the only variable that can be increased indefinitely to produce any desired degree of immunity from signal imitation. In the interests of speed of signalling and loading of amplifiers, it is, however, desirable to limit the delay time to the smallest possible value. The curves given enable some estimate to be made of its effect under the conditions likely to occur in practice.

It is not suggested that the data obtained from the idealized receiver used in these tests apply accurately to all the various practical designs of receiver. The assumption is made that, for example, different guard coefficients for one design will give relatively the same results as the same guard coefficients for another design. It is suggested that receiver design be guided by the data given here, and that practical trial be used to confirm, for a receiver to work in a system to Comité Consultatif International Téléphonique recommendations, that the immunity from signal imitation is adequate with the delay times included in the recommendations; also to determine for receivers to work in other systems, the delay times necessary to achieve the desired degrees of immunity from signal imitation.

One further point on delay time is worth recording. It has been found by experiment with a commercial receiver, that delay time, measured as the time that the make contact of the receiver relay is closed, gives very much less signal imitation than the same time measured as the time that the break contact is open. The explanation of this effect appears to be that although the transit time of the contact was only about 1 millisecond under genuine signalling conditions, it was very much greater under signal-imitation conditions, as may readily be understood.

### 7.2 TWO-PULSE SIGNALS

Of considerable interest is the two-pulse signal composed of a compound pulse followed without a break by a pulse at one of the frequencies making up the compound pulse. The first pulse splits the connection and the second causes an effective signal that must not be imitated by speech. The Comité Consultatif International Téléphonique has recommended a splitting time of 60 milliseconds maximum, and a delay time on the second pulse not less than 30 milliseconds. To test whether this signal is really speech-immune would take months of observation. A result almost as satisfactory can be obtained by positive data with less secure conditions, as follows. With guard coefficient equal to 0.53 and signal-circuit sensitivity  $-30$  decibels, the number of times various lengths of first-pulse signals combined with various lengths of second-pulse signals were imitated was measured with the results shown in Table 3.

TABLE 3

Compound Pulse Length in Milliseconds	Frequency of Second Pulse	Number of Imitations per Speech Hour with Second Pulse Delay Time in Milliseconds				Duration of Test in Speech Hours
		5	10	20	40	
30	2000	1	0.5	0.16	—	6
40	2000	1	0.6	0.3	0	10
60	2000	0	0	0	0	6
40	2400	0	0	0	0	5

These results indicate that there should be no difficulty in providing perfect protection against signal imitation with the Comité Consultatif International Téléphonique recommended pulse lengths for the two-frequency signalling code.

It has been debated whether as a further measure of protection against voice imitation the compound-frequency prefix should be separated from the simple-frequency operative signal by a silent space, thus in effect producing a three-pulse signal; but this appears to be an unnecessary complication of the signal generation and reception circuits.

### 8. Conclusions

Based largely on the signal-imitation tests described here and the transmission characteristics of present and future telephone circuits in Europe, the Comité Consultatif International Téléphonique has chosen frequencies in the band 2000 to 2500 cycles for international voice-frequency signalling.

With these frequencies, and probably with any others, the variables investigated have the following effects on signal imitation:

A. Guard coefficient has a major effect; the coefficient should be as high as possible but is limited by signal interference.

B. Delay time is of major importance but has to be limited in the interests of speed of signalling.

C. Compound and two-pulse operation have major and beneficial effects.

D. Signal-circuit bandwidth within the limits usually desired has minor effects on signal imitation and signalling speed.

E. Signal-circuit sensitivity has only a very small direct effect when signal imitation has been reduced to small proportions by other factors; to reduce line-amplifier loading, a high sensitivity and low signal level would be desirable if they did not indirectly increase signal imitation by reducing the signal-to-noise ratio and thereby limit the guard coefficient.

F. Hangover time has no influence on signal imitation; it should be made as small as possible because of its effect on signal interference.

G. No single factor is by itself powerful enough to prevent signal imitation, and, for any given signalling system, a combination of factors must be chosen to prevent signal imitation or reduce it to an acceptable value.

Blocking amplifiers increase signal imitation by an amount that is small for the chosen frequencies and is likely to diminish as transmission systems improve.

It will be appreciated, and the authors are only too well aware, that the conclusions rest on premises that include disputable assumptions, and that the data are far from complete. These criticisms are, it is felt, inherent in the character



of the problem and the enormous labour involved in obtaining the data. It is thought that the value of the work lies in the greater confidence that can now be attached to any choice of frequencies for signalling, and in the help it gives to designers of voice-frequency systems by knowing what advantage is to be gained from certain features, or lost by not making use of those features, when faced, as designers invariably are, with having to make decisions such as those concerning cost and signalling speed.

9. Acknowledgments

The authors wish to express their thanks to the Engineer-in-Chief of the Post Office and to Standard Telecommunication Laboratories, Limited, for permission to publish the information contained in the paper. They are also glad of the opportunity to thank the many European telephone administrations who participated in the work, and particularly the Swiss administration for the facilities and help afforded at Zürich.

Their sincere thanks for helpful suggestions throughout the tests and in the preparation of the paper are due to Dr. W. G. Radley, Mr. E. P. G. Wright, and Monsieur H. Jacot, also to the team who carried out the actual tests, comprising Messrs. Spinks, Faulkner, Hauser, Gould, Brown, and Odell, and to the many other colleagues too numerous to mention by name.

10. References

1. W. G. Radley and E. P. G. Wright, "Voice-Frequency Signalling and Dialling in Long-Distance Telephony," *Journal of the Institution of Electrical Engineers*, v. 89, Part III, p. 43; 1942.
2. B.S. 204—"Glossary of Terms used in Telecommunication;" 1943.
3. Comité Consultatif International Téléphonique, *Livre Blanc*, v. 1 (ter), p. 87; 1938.
4. Comité Consultatif International Téléphonique: "Programme Général D'Interconnexion Téléphonique en Europe (1947-1952)," p. 42; Montreux, 1946.
5. Comité Consultatif International Téléphonique: 8th Commission de Rapporteurs Document No. 16, 1947/48.
6. Research Report No. 12626 of the British Post Office: "Voice Frequency Signalling: Signal Imitation Tests;" 1946.
7. International Telecommunication Laboratories Report S. No. 22: "Signal Imitation Tests in Switzerland;" 1947.

8. Research Report No. 12890 of the British Post Office: "Voice Frequency Signalling—Signal Imitation Tests on Receivers;" 1948.
9. D. P. Loye and K. C. Morgan, "Sound Picture Recording and Reproducing Characteristics," *Journal of the Society of Motion Picture Engineers*, v. 32, p. 631; 1939.

Items 6, 7, and 8 are restricted reports, not generally available.

11. Appendix—Terms Used in Defining Sensitivity of Guard Circuit

Figure 8 shows the characteristics of the signal and guard circuits of receivers of the type to which the paper refers. Each curve indicates the voltage output for a constant-voltage simple-frequency input at different frequencies. Curves 1 and 2 refer to two signal circuits and are of equal height *A* at the frequencies  $f_1$  and  $f_2$  of maximum sensitivities of the two circuits. Curve 3 is that of an aperiodic guard circuit and has an output *B* at all frequencies. Curve 4 represents a guard circuit that has an output *C* at the frequency of maximum sensitivity  $f_3$ .

"Critical ratio" was a term used with aperiodic guard circuits and was defined as the ratio *B:A*. This definition sufficed for testing equipment, as used in the first series of tests, which did not have to satisfy a receiver performance specification.

Aperiodic guard circuits are not always suitable for receivers and a more general form is that shown as curve 4. The term "guard ratio" was then introduced and defined as the ratio *C:A*. This definition has caused some difficulties in interpretation, and for this reason the term "guard coefficient" is now used and defined as in Section 2. The numerical equivalents of the three terms when a mean rectified voltage is used for the output from the guard circuit are given in Table 4.

TABLE 4

Critical Ratio	Guard Ratio	Guard Coefficient
0.5	0.5	0.53
0.7	—	0.77
0.8	—	1.04
—	1.0	1.06
0.9	—	1.58
—	2.0	2.13
0.95	—	2.17

# Impedance Measurements with Directional Couplers and Supplementary Voltage Probe\*

By B. PARZEN

*Federal Telecommunication Laboratories, Incorporated, Nutley, New Jersey*

IMPEDANCE measurements may be made at very-high frequencies and above with the impedometer, consisting of two oppositely connected directional couplers and a voltage probe in a short transmission line. An experimental model for frequencies between 50 and 500 megacycles per second is described.

• • •

Directional couplers have been used to determine the magnitude of the reflection coefficient (and hence standing-wave ratio) of impedances referred to a given transmission line.<sup>1</sup> The addition of a voltage probe permits the phase angle and magnitude of the reflection coefficient to be determined, from which the real and imaginary components of the impedance may be obtained.

The essential components of the equipment are shown in Figure 1. The impedance  $Z_L$  to be measured is connected by a short length of transmission line to a generator, preferably through an attenuating pad. Two directional couplers are inserted anywhere in the line. One, giving an output  $E_2$ , is directed to the reflected wave and the other, of output  $E_3$ , to the forward wave. A voltage probe, giving an output  $E_1$ , is inserted in the line at electrical degrees  $\theta_1$  from  $Z_L$ .

The attenuating pad maintains  $E_3$  substantially independent of the load  $Z_L$ , and is not required if the internal impedance of the generator is equal to the characteristic impedance of the line.

## 1. Theory of Operation

What the equipment directly measures is the reflection coefficient  $K$  and not the impedance. The relations at any point  $\alpha$  on the line between

the reflection coefficient  $K_\alpha$  and the normalized impedance  $z$ , equal to the actual impedance  $Z_\alpha$  divided by the characteristic impedance of the line  $Z_0$ , are given by

$$z_\alpha = r_\alpha + jx_\alpha = \frac{1}{y_\alpha} = \frac{1}{g_\alpha + jb_\alpha} = \frac{1 + K_\alpha}{1 - K_\alpha}, \quad (1)$$

$$K_\alpha = |K| e^{j\theta_\alpha} = \frac{z_\alpha - 1}{z_\alpha + 1} = \frac{1 - y_\alpha}{1 + y_\alpha}. \quad (2)$$

From well-known transmission-line and directional-coupler theory, we have

$$E_1 = C_1 \underline{E}_1 (1 = K_1), \quad (3A)$$

$$E_2 = C_2 \underline{E}_2 K_2, \quad (3B)$$

$$E_3 = C_3 \underline{E}_3,$$

where  $C_1$ ,  $C_2$ , and  $C_3$  are constants and  $\underline{E}$  indicates the forward components of the voltage wave in the transmission line.

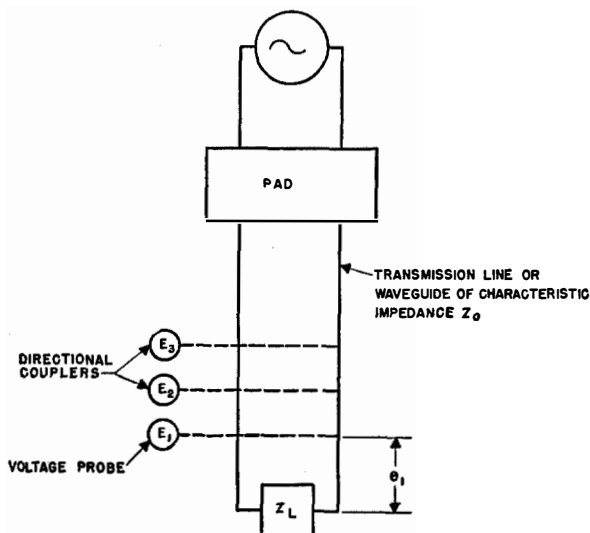

Figure 1—Essential components of impedometer.

\* Reprinted from *Proceedings of the I.R.E.*, v. 37, pp. 1208-1211; October, 1949. Presented, Institute of Radio Engineers National Convention, New York, New York, March 24, 1948.

<sup>1</sup> B. Parzen and A. Yalow, "Theory and Design of the Reflectometer," *Electrical Communication*, v. 24, pp. 94-100; March, 1947.

After making  $C_1$ ,  $C_2$ , and  $C_3$  equal to each other, we obtain from (2) and (3)

$$\frac{1}{z_\alpha} = y_\alpha = g_\alpha + jb_\alpha = \frac{1 - K_\alpha}{1 + K_\alpha}$$

$$|e_1| = \left| \frac{E_1}{E_3} \right| = |1 + K_1|$$

$$= \left| 1 + |K| \cos \delta_1 + j|K| \sin \delta_1 \right|, \quad (4)$$

$$= \frac{1 - |K|^2 - 2|K| \sin \delta_\alpha}{1 + |K|^2 + 2|K| \cos \delta_\alpha}, \quad (7)$$

$$|e_2| = \left| \frac{E_2}{E_3} \right| = |K|. \quad (5)$$

$$|e_1|^2 = |1 + K_1|^2 = \frac{4}{(1 + g_1)^2 + b_1^2}, \quad (8)$$

$$|e_2|^2 = |K|^2 = 1 - \frac{4g_1}{(1 + g_1)^2 + b_1^2}. \quad (9)$$

From (1), (2), (4), and (5) result

$$\cos \delta_1 = \frac{|e_1|^2 - |e_2|^2 - 1}{2|e_2|}, \quad (6)$$

From (5) and (6), the magnitude  $|K|$  and phase angle  $\delta_1$  of the reflection coefficient at the

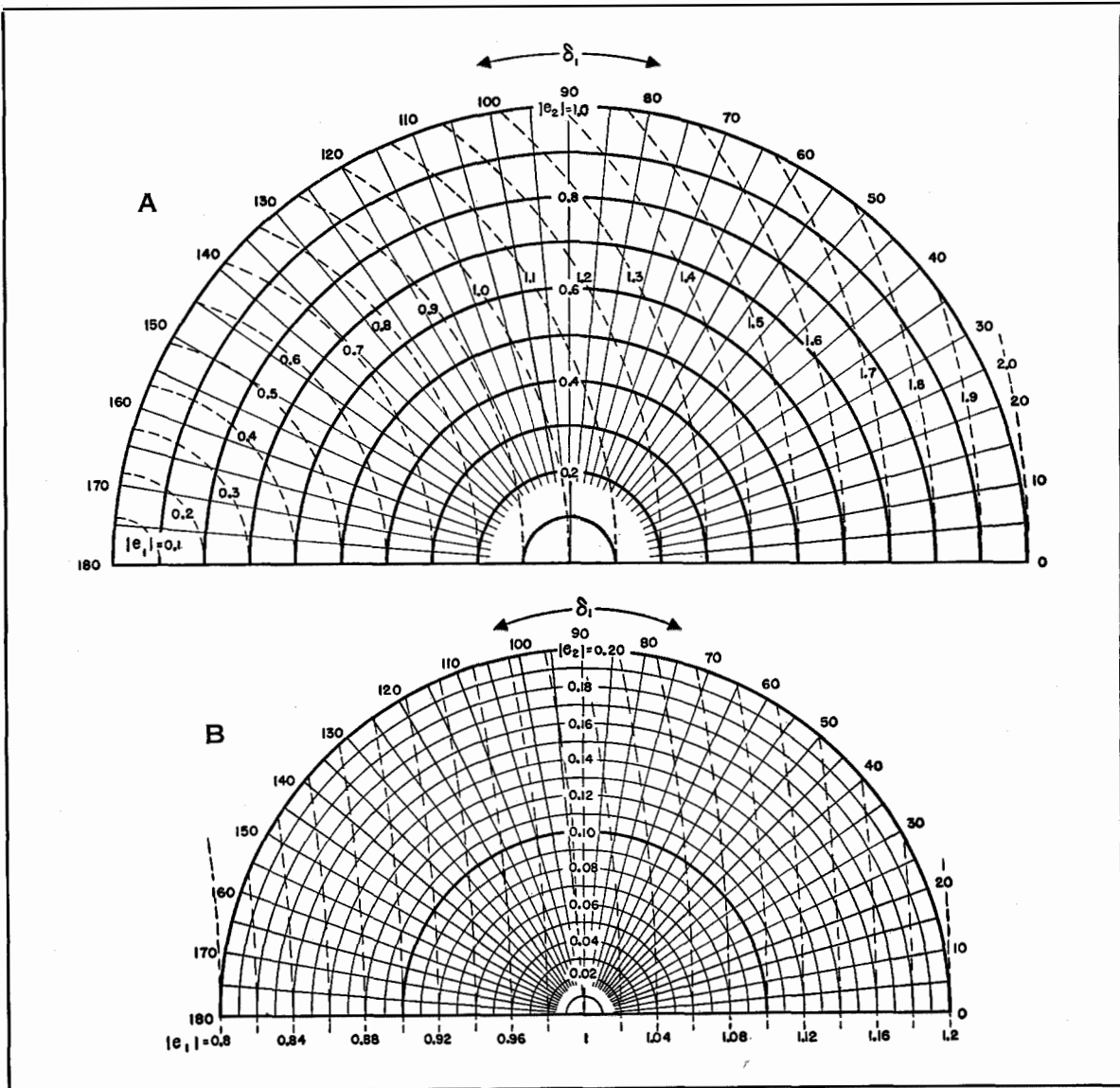

Figure 2—Plot of  $|e_1|$ ,  $|e_2|$ , and  $\delta_1$ , in (A) for  $|e_2| = 0.2$  to 1 and in (B) for  $|e_2| = 0.01$  to 0.2.

point of the voltage probe may be calculated. We can calculate the angle  $\delta_L$  at the load from the relation

$$\delta_L = \delta_1 + 2\theta_1. \quad (10)$$

If  $2\theta_1$  is not known, it may be found easily as follows: (A) Short the end of the line for which load  $|e_2| = 1$  and  $\delta_L = 180$  degrees, and read  $e_1$ ; then (B) calculate  $\delta_1$  from (6); and (C)  $2\theta_1 = 180 - \delta_1$ .

coefficient is large and the change in  $|e_2|$  is greater when the reflection coefficient is small. In every case, the change in either  $|e_1|$  or  $|e_2|$  will be sufficient to fix the sign of  $\delta_1$  positively.

The procedure to be followed in measuring an impedance is: (A) Connect the unknown impedance to the equipment; (B) read  $E_1$ ,  $E_2$ , and  $E_3$ ; (C) find the sign of  $\delta$ , by inserting the susceptance and noting the change in readings; (D) calcu-

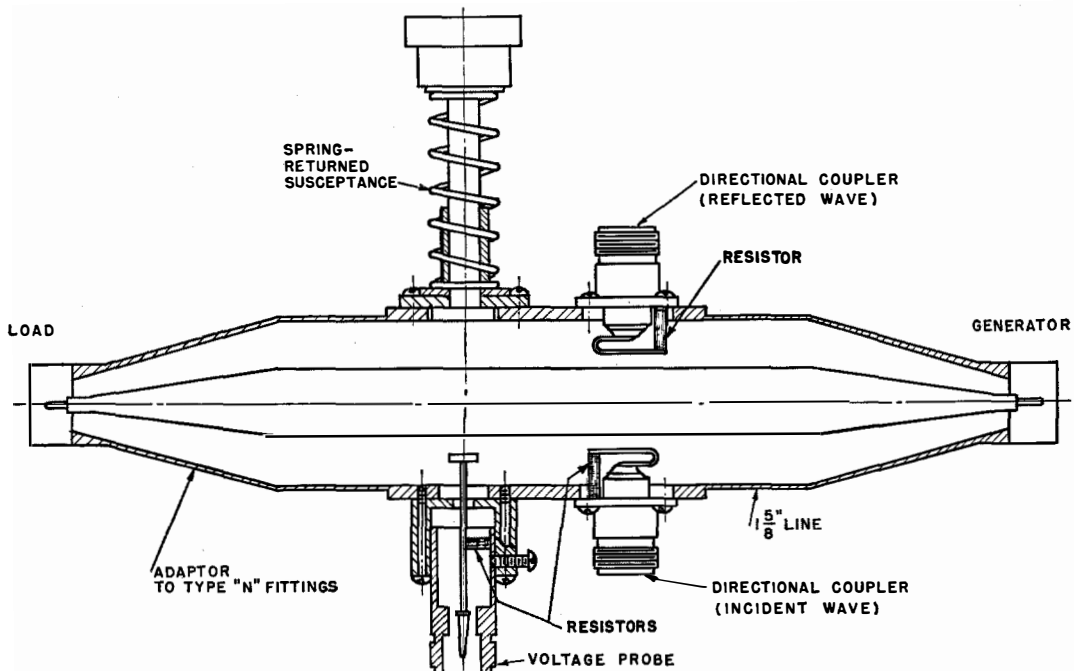

Figure 3—Cross-sectional view of impedometer.

Equation (6) is incomplete in that it permits the determination of only the magnitude of  $\delta_1$  and not its sign since, in general,  $\cos \delta = \cos (-\delta)$ . An additional component is, therefore, added to obtain the sign of  $\delta_1$ . For convenience, the component consists of a capacitive susceptance  $j\mathbf{b}$  at the point of the voltage probe. The susceptance is normally out of the line and is inserted into the line and its effect noted after  $E_1$ ,  $E_2$ , and  $E_3$  have been measured. Equations (7), (8), and (9) show that  $|e_1|$  increases and  $|e_2|$  decreases when  $\delta_1$  is positive and conversely when  $\delta_1$  is negative. Thus, by noting the change in  $|e_1|$  and/or  $|e_2|$ , the sign of  $\delta_1$  is determined. Equations (8) and (9) also indicate that the effective change in  $|e_1|$  is greater when the reflection

late  $|K|$  from (5) and  $\delta_1$  from (6); (E) add  $\delta_1$  to  $2\theta_1$  and obtain  $\delta_L$  (if  $2\theta_1$  is not known, it is found as described above); and (F) calculate  $z$  from (7), using Smith or equivalent impedance charts.

To minimize labor in calculating  $\delta_1$  from (6), that equation has been plotted in Figure 2. It may be noted that (6) is but an expression of the cosine law for triangles.

This method is practical at *all* frequencies, since all the components (directional couplers, voltage probe, variable capacitive susceptance, and short section of transmission line) have been built at *all* radio frequencies. The method is particularly useful for measurements between 50 and 500 megacycles per second in view of the absence of other good methods for this frequency region.

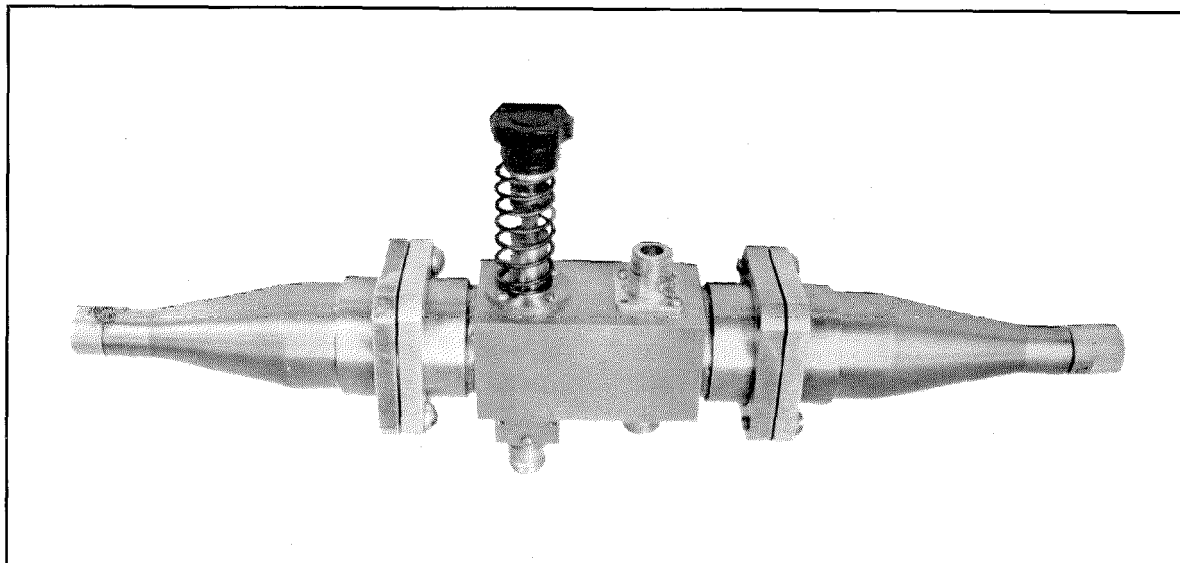

Figure 4—Experimental model of impedometer.

## 2. Experimental Model

A cross-sectional view of an impedometer for use from 50 to 500 megacycles is shown in Figure 3 and a photograph in Figure 4. It consists of a short section of  $1\frac{5}{8}$ -inch coaxial line with adapters for type-N fittings. In this line, are placed two wide-band directional couplers, a capacitive voltage probe, and a variable susceptance made up of a high-capacitance probe that can be inserted by a spring-returned push button. The length of the action portion is 5 inches and the total length, including the adapters, is 15 inches.

Each coupler consists of a resistor, capacitor, and loop. They differ only in the orientation of the loop with respect to the line. Their theory of operation has been fully covered in the referenced paper.

The coupler characteristics are as follows.

### 2.1 INTERNAL IMPEDANCE

The internal impedance is approximately 50 ohms.

### 2.2 DIRECTIVITY

The directivity is approximately 40 decibels. By directivity is meant the value of  $|e_2|^2$  expressed in decibels when the line is terminated by  $Z_0$ . The directivity is important as it fixes the lowest value of reflection coefficient that can be measured. Thus, a directivity of 40 decibels

corresponds to a minimum reflection coefficient of 0.01, which is equivalent to a voltage standing-wave ratio of 1.02. For the type of couplers shown, a directivity of 35 decibels and better can be readily obtained.

### 2.3 COUPLING

The coupling is approximately  $-40$  decibels at 100 megacycles. The coupling decreases 6 decibels as the frequency decreases by an octave. By coupling is meant the ratio in decibels of the power obtained from the  $E_3$  coupler to the power absorbed by the impedance being measured, when the impedance is equal to  $Z_0$ . The coupling should be as small as possible, for as it increases, so do the distortion of the field within the line and the measurement errors. It will be noted that the impedometer as presently constructed has a coupling of  $-25$  decibels at 500 megacycles. However, the coupling can be easily decreased by reducing both the inductive and capacitive couplings.

### 2.4 VOLTAGE PROBE

The voltage probe consists of a small capacitance in series with a low resistance. The degree of coupling is adjusted by moving the probe in or out to vary the capacitance. When properly adjusted, the internal impedance and attenuation characteristics of the probe are identical to those

of the couplers. Thus, correct probe adjustment at any frequency insures correct adjustment at all frequencies.

### 2.5 TRANSMISSION LINE

The transmission line has a characteristic impedance of 53 ohms. For maximum accuracy, the impedometer should be used without the adapters. The voltage standing-wave ratio of the impedometer with both adapters is 1.05.

### 2.6 ADJUSTABLE SUSCEPTANCE

The adjustable susceptance consists of a grounded variable-capacitance probe, which can be inserted into the line by a spring-returned mechanism. On inserting the probe, both  $E_1$  and  $E_2$  change. As previously explained, the change in  $E_2$  is greater when the voltage standing-wave ratio is low and the change in  $E_1$  is greater when the voltage standing-wave ratio is high. In every case, the change in either  $E_1$  or  $E_2$  is sufficient to fix positively the sign of  $\delta_1$ .

On initial use of the impedometer, the following should be checked:

$$\begin{aligned} E_1 &= E_3 \text{ when the load is equal to } Z_0, \\ E_2 &= 0 \text{ when the load is equal to } Z_0, \\ E_2 &= E_3 \text{ when the load is a short circuit.} \end{aligned}$$

When these conditions are established, we can be certain of the correct operation of the impedometer. The impedometer possesses fair accuracy when the reflection coefficient of the impedance being measured has a magnitude between 0.02 and 0.95 at any phase angle.

### 3. Impedance Measurements

Impedance measurements made with the impedometer at 100 megacycles have been found to be within 5 percent of those obtained with a slotted line. At this frequency, the required minimum length of the slotted line is 60 inches compared with the 5-inch active length of the impedometer.

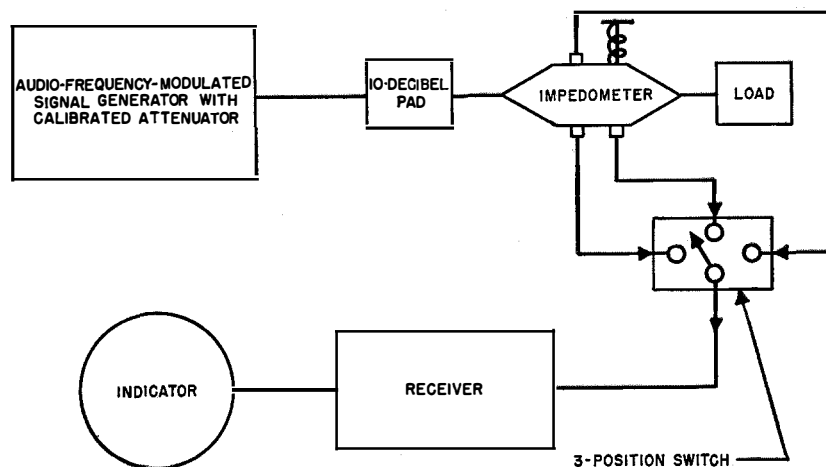

Figure 5—Block diagram for impedance measurements.

The equipment arrangement as illustrated in Figure 5 and the following procedure makes indicators having precise amplitude calibrations unnecessary.

A. A standard-signal generator having a maximum calibrated output of 100,000 microvolts was used. The attenuator was accurately calibrated over a range from +40 to -10 decibels referred to 1000 microvolts. The modulation was at 400 cycles.

B. The detector was a standard communications receiver, having sufficient selectivity so that generator harmonics are not troublesome.

C. A 10-decibel resistive attenuator was inserted between the generator and the impedometer to insure constancy of  $E_3$  regardless of the impedance being measured.

D. The impedance to be measured was connected to the impedometer, and the attenuator was set to 1000 microvolts. The output of the receiver was noted when it was connected to the  $E_3$  probe. The values of the attenuator settings required to yield the identical receiver output when connected to the  $E_1$  and  $E_2$  probes determine the magnitude of  $E_1$  and  $E_2$ .

E. The impedance is then calculated in the manner previously described. The accuracy is thus determined almost entirely by the quality of the impedometer probes and by the calibration of the signal-generator attenuator; fairly accurate measurements are, therefore, not too difficult to achieve.

Although the impedometer has been specifically designed for the frequency band of 50 to

500 megacycles, it is usable at much lower frequencies, being limited only by the attenuation of the coupler, which increases 6 decibels per octave decrease in frequency. Where sufficiently powerful signal generators and sufficiently sensitive receivers are available, this limitation is not serious. For example, at 3 megacycles, a generator having a maximum output of 1 volt and a receiver sensitivity of 5 microvolts will be suitable.

To summarize, the basic principles of the im-

pedometer are applicable at all frequencies. However, the availability of good bridges at frequencies below 50 megacycles, restricts its application to the higher frequencies. It is particularly useful between 50 and 500 megacycles as: (A) It covers a very-wide frequency band; (B) it is a low-cost instrument; (C) except for the slotted line, no other simple instrument is available; and (D) slotted lines for this frequency region are too bulky and expensive.

## Contributors to This Issue



E. M. DELORAINE

E. M. DELORAINE was born in Paris, France on May 16, 1898. He received from the Paris University his B.S. and Certificate of Mathematics in 1916, then from the "Ecole Supérieure de Physique et Chimie" their Diploma in Physics in 1921. His studies were interrupted in the spring of 1917 when he joined the French Army Signal Corps to be later engaged in research work at the Eiffel Tower. In 1949, he received his Doctorate from the Paris University.

He became associated with the London engineering staff of the International Western Electric Company in 1921 and began technical work in connection with wire transmission and radio systems. From 1923 to 1926,

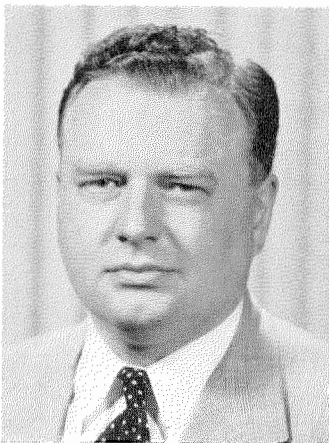

SVEN H. DODINGTON

he was responsible for part of the developments in Great Britain in connection with the first transatlantic telephone circuit.

Dr. Deloraine was charged with the establishment in Paris of a regional research laboratory in 1927. He was made European technical director of International Standard Electric Corporation in 1933. During this period, he made various contributions in the very-high- and ultra-high-frequency fields and also in the advancement of single-sideband high-frequency communication and high-power broadcasting. Dr. Deloraine further took a special interest in directing experiments in connection with automatic radio direction finders, radio aids to navigation, and in the application of pulse technique to communication systems.

Dr. Deloraine came to the United States at the end of 1940 to organize a laboratory unit for Federal Telephone and Radio Corporation. This laboratory contributed during the war, in particular, to the development of long-distance detection of airplanes and ships by high-frequency direction finding, also to the development of instrument landing systems.

In 1945, Dr. Deloraine was appointed president of International Telecommunication Laboratories and in 1946 technical director of the International Telephone and Telegraph Corporation as well as vice president and technical director of the International Standard Electric Corporation. He is now also president of Laboratoire Central de Télécommunications, Paris, and vice chairman of Standard Telecommunication Laboratories, London.

Dr. Deloraine was made a Chevalier of the Legion of Honor in 1938 and an Officer in 1949. He is an officer of several scientific societies abroad. In the United States, he is a Fellow of the Institute of Radio Engineers and was vice president in 1949, and is also a Fellow of the American Institute of Electrical Engineers.

("Pulse Modulation" by Dr. Deloraine appeared on pages 222-227 of the September, 1949, issue.)



T. H. FLOWERS

SVEN H. DODINGTON was born on May 22, 1912, in Vancouver, British Columbia, Canada. After early schooling in Denmark, England, and the United States, he received the A.B. degree from Stanford University in 1934.

In 1935, he went to Scophony, Limited, in London and was transferred to New York City in 1940. The next year, he joined the laboratories division of International Telephone and Radio Manufacturing Corporation. He is now a department head specializing in interrogator-responser systems for Federal Telecommunication Laboratories.

• • •



A. FROMAGEOT





EDWIN ISTVÁNFY

ANTOINE FROMAGEOT was born on October 27, 1910, in Paris, France. He studied at the Ecole Polytechnique until 1932. In 1934, he received the degree of electrical engineer at the Ecole Supérieure d'Electricité (Paris), and spent the next year at the Cavendish Laboratory of Cambridge University.

Mr. Fromageot joined the Société Anonyme Lignes Télégraphiques et Téléphoniques in 1936; he was later placed in charge of development work related to coaxial and 12-channel carrier cables. In 1943, he was transferred to the Laboratoire Central de Télécommunications, where he is now directing development work on carrier telephony.



MARC A. LALANDE

MARC A. LALANDE was born in Paris, France, on October 13, 1896. He received the B.S. degree and was admitted to the Ecole de Physique et Chimie, a branch of Paris University, in 1915. The war interrupted his studies and he served in the artillery and signal corps of the French army until 1919. He received the diploma of engineer in 1921.

After serving as an engineer for Société d'Etude pour Lignes Télégraphiques et Téléphoniques à Longue Distance, he joined Le Matériel Téléphonique in 1924. He was transferred in 1935 to Laboratoire Central de Télécommunications, where he now specializes in line and carrier transmission problems for telephony, television, and remote-control systems.

T. H. FLOWERS received the B.Sc. (Hons.) degree. He became an engineering apprentice at the Royal Arsenal in 1922.

In 1926, he joined the British Post Office engineering staff, receiving an appointment to the research branch four years later. He collaborated in the design of the Post Office two-voice-frequency signaling system, and is presently engaged in work on long-distance national and international signaling and on electronic switching.

Mr. Flowers was awarded the M.B.E. for his war work. He is a member of the Institution of Electrical Engineers and has been actively associated with the work of the Comité Consultatif International Téléphonique.

EDWIN ISTVÁNFY was born in January, 1895. He received the M.Sc. degree in 1922 from the Technical University of Budapest, Hungary.

In 1923, he joined the engineering staff of the United Incandescent Lamp and Electrical Company, Limited.

Since 1928, he has been with the Standard Electric Company, Limited, in Budapest. In 1938, Mr. Istvánffy became technical director of the company. Most of his work has been in the radio field.

ARMIG G. KANDOIAN was born in Van, Armenia, on November 28, 1911. He received the B.S. degree in 1934 and a year later the M.S. degree in electrical communication engineering from Harvard University.

Since 1935, Mr. Kandoian has been with the International Telephone and Telegraph System. He has done extensive work in the antenna, aerial-navigation, radar, and communication fields. At present, he is head of the radio and radar components division of Federal Telecommunication Laboratories.

Mr. Kandoian received the honorable mention award in the Eta Kappa Nu recognition of outstanding young electrical engineers for 1943. He is a member of the Tau Beta Pi, Harvard Engineering Society, Institute of Radio Engineers, and American Institute of Electrical Engineers.

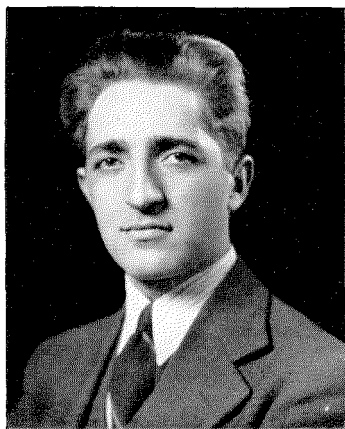

ARMIG G. KANDOIAN



ARNOLD M. LEVINE

ARNOLD M. LEVINE was born on August 15, 1916, at Preston, Connecticut. In 1940, he received the M.S. degree in electrical engineering from the University of Iowa.

On graduation, he joined the sound laboratories of Columbia Broadcasting System. In 1942, he came to Federal Telecommunication Laboratories, where he has been engaged in work on broad-band intermediate- and video-frequency amplifiers, display circuits, and pulse-time multiplex systems. He is now a department head in the communications division.

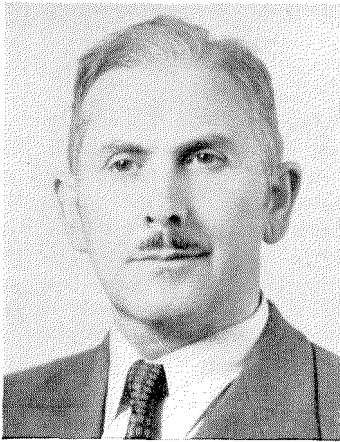

H. STOERI

Mr. Levine is a member of the Institute of Radio Engineers.

• • •

H. STOERI was born in Switzerland. He graduated as an electrical engineer in 1916 and entered the service of Bell Telephone Manufacturing Company in Antwerp, Belgium, as a tester on automatic telephone installations. From 1926 to 1940, he was assistant installation head and participated in the first 7A, 7D, and rotary automatic toll equipment installations. In 1940, he transferred to Standard Telephones et Radio S.A. in Zurich, Switzerland, where he is in charge of the switching section.

• • •

DONALD ADAMS WEIR was born at Upton, Chester, England on July 17, 1912. He attended Liverpool Technical College and received First Class City and Guilds Certificates in telephony and the Higher National Certificate in electrical engineering.

After apprenticeship to H. T. Bothroyd Limited, he worked for the Automatic Telephone and Electric Company. In 1939, he joined the Air Ministry Telecommunications Research Establishment.

In 1946, he became a staff member of the newly formed Standard Telecommunication Laboratories and is now engaged in signaling and switching research.

Mr. Weir is an Associate Member of the Institution of Electrical Engineers.

• • •

For a biography and photograph of B. Parzen, see page 264 of the September, 1949, issue.

• • •



DONALD A. WEIR

# INTERNATIONAL TELEPHONE AND TELEGRAPH CORPORATION

## Associate Manufacturing and Sales Companies

### United States of America

International Standard Electric Corporation, New York, New York  
Federal Telephone and Radio Corporation, Clifton, New Jersey  
International Standard Trading Corporation, New York, New York  
Capehart-Farnsworth Corporation, Fort Wayne, Indiana

### Great Britain and Dominions

Standard Telephones and Cables, Limited, London, England  
Branch Offices: Birmingham, Bristol, Leeds, Manchester, England; Glasgow, Scotland; Dublin, Ireland; Cairo, Egypt; Calcutta, India; Karachi, Pakistan; Johannesburg, South Africa; Salisbury, Rhodesia  
Creed and Company, Limited, Croydon, England  
International Marine Radio Company Limited, Croydon, England  
Kolster-Brandes Limited, Sidcup, England  
Standard Telephones and Cables Pty. Limited, Sydney, Australia  
Branch Offices: Melbourne, Australia; Wellington, New Zealand  
Silovac Electrical Products Pty. Limited, Sydney, Australia  
Austral Standard Cables Pty. Limited, Melbourne, Australia  
New Zealand Electric Totalisators Limited, Wellington, New Zealand  
Federal Electric Manufacturing Company, Ltd., Montreal, Canada

### South America

Compañía Standard Electric Argentina, Sociedad Anónima, Industrial y Comercial, Buenos Aires, Argentina  
Standard Electrica, S.A., Rio de Janeiro, Brazil  
Compañía Standard Electrica, S.A.C., Santiago, Chile

### Europe and Far East

Vereinigte Telephon- und Telegraphenfabriks Aktien-Gesellschaft Czeija, Nissl & Company, Vienna, Austria  
Bell Telephone Manufacturing Company, Antwerp, Belgium  
China Electric Company, Limited, Shanghai, China  
Standard Electric Aktieselskab, Copenhagen, Denmark  
Compagnie Générale de Constructions Téléphoniques, Paris, France  
Le Matériel Téléphonique, Paris, France  
Les Téléprimeurs, Paris, France  
Ferdinand Schuchhardt Berliner Fernsprech und Telegraphenwerk Aktiengesellschaft, Berlin, Germany  
C. Lorenz, A.G. and Subsidiaries, Berlin, Germany  
Mix & Genest Aktiengesellschaft and Subsidiaries, Berlin, Germany  
Süddeutsche Apparatefabrik Gesellschaft m.b.H., Nuremberg, Germany  
Telephonfabrik Berliner A.G. and Subsidiaries, Berlin, Germany  
Nederlandsche Standard Electric Maatschappij N.V., Hague, Netherlands  
Dial Tele onkereskedelmi Részvény Társaság, Budapest, Hungary  
Standard Villamossági Részvény Társaság, Budapest, Hungary  
Telefongyár r.t., Budapest, Hungary  
Fabbrica Apparechiature per Comunicazioni Elettriche, Milan, Italy  
Standard Telephone og Kabelfabrik A/S, Oslo, Norway  
Standard Electrica, Lisbon, Portugal  
Compañía Radio Aérea Marítima Española, Madrid, Spain  
Standard Eléctrica, S.A., Madrid, Spain  
Aktiebolaget Standard Radiofabrik, Stockholm, Sweden  
Standard Telephone et Radio S.A., Zurich, Switzerland

### Telephone Operating Systems

Compañía Telefónica Argentina, Buenos Aires, Argentina  
Compañía Telefónica Comercial, Buenos Aires, Argentina  
Compañía Telefónica del Plata, Buenos Aires, Argentina  
Companhia Telefonica Paranaense S.A., Curitiba, Brazil  
Companhia Telefonica Rio Grandense, Porto Alegre, Brazil  
Compañía de Telefonos de Chile, Santiago, Chile  
Compañía Telefónica de Magallanes S.A., Punta Arenas, Chile  
Cuban American Telephone and Telegraph Company, Havana, Cuba  
Cuban Telephone Company, Havana, Cuba  
Mexican Telephone and Telegraph Company, Mexico City, Mexico  
Compañía Peruana de Telefonos Limitada, Lima, Peru  
Porto Rico Telephone Company, San Juan, Puerto Rico  
Shanghai Telephone Company, Federal Inc. U.S.A., Shanghai, China

### Radiotelephone and Radiotelegraph Operating Companies

Compañía Internacional de Radio, Buenos Aires, Argentina  
Compañía Internacional de Radio Boliviana, La Paz, Bolivia  
Companhia Radio Internacional do Brasil, Rio de Janeiro, Brazil  
Compañía Internacional de Radio, S.A., Santiago, Chile  
Radio Corporation of Cuba, Havana, Cuba  
Radio Corporation of Porto Rico, San Juan, Puerto Rico

### Cable and Radiotelegraph Operating Companies

(Controlled by American Cable & Radio Corporation, New York, New York)

The Commercial Cable Company, New York, New York<sup>2</sup>  
Mackay Radio and Telegraph Company, New York, New York<sup>3</sup>  
All America Cables and Radio, Inc., New York, New York<sup>4</sup>  
Sociedad Anónima Radio Argentina, Buenos Aires, Argentina<sup>5</sup>

<sup>2</sup>Cable service. <sup>3</sup>International and marine radiotelegraph services.  
<sup>4</sup>Cable and radiotelegraph services. <sup>5</sup>Radiotelegraph service.

### Laboratories

Federal Telecommunication Laboratories, Inc., Nutley, New Jersey  
Standard Telecommunication Laboratories, Limited, London, England

Laboratoire Central de Télécommunications, Paris, France